



US 20110012394A1

(19) **United States**

(12) **Patent Application Publication**

**Furman**

(10) **Pub. No.: US 2011/0012394 A1**

(43) **Pub. Date: Jan. 20, 2011**

(54) **BABY SEAT SLING FOR SUSPENDING A  
BABY SEAT FROM A STRUCTURE**

(60) Provisional application No. 61/116,006, filed on Nov. 19, 2008.

(76) Inventor: **Mark Furman**, Barrington, IL (US)

**Publication Classification**

Correspondence Address:  
**ELLIOT FURMAN**  
15 WEST 81ST STREET #11J  
NEW YORK, NY 10024 (US)

(51) **Int. Cl.**  
*A47D 1/10* (2006.01)  
*A47D 15/00* (2006.01)

(52) **U.S. Cl.** ..... 297/183.1; 297/273

(57) **ABSTRACT**

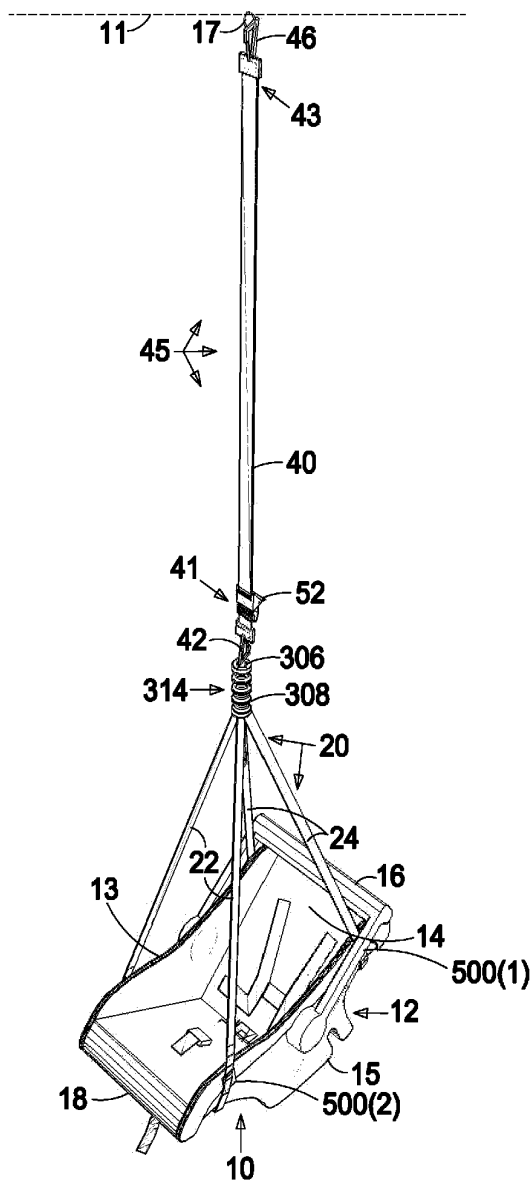
(21) Appl. No.: **12/785,029**

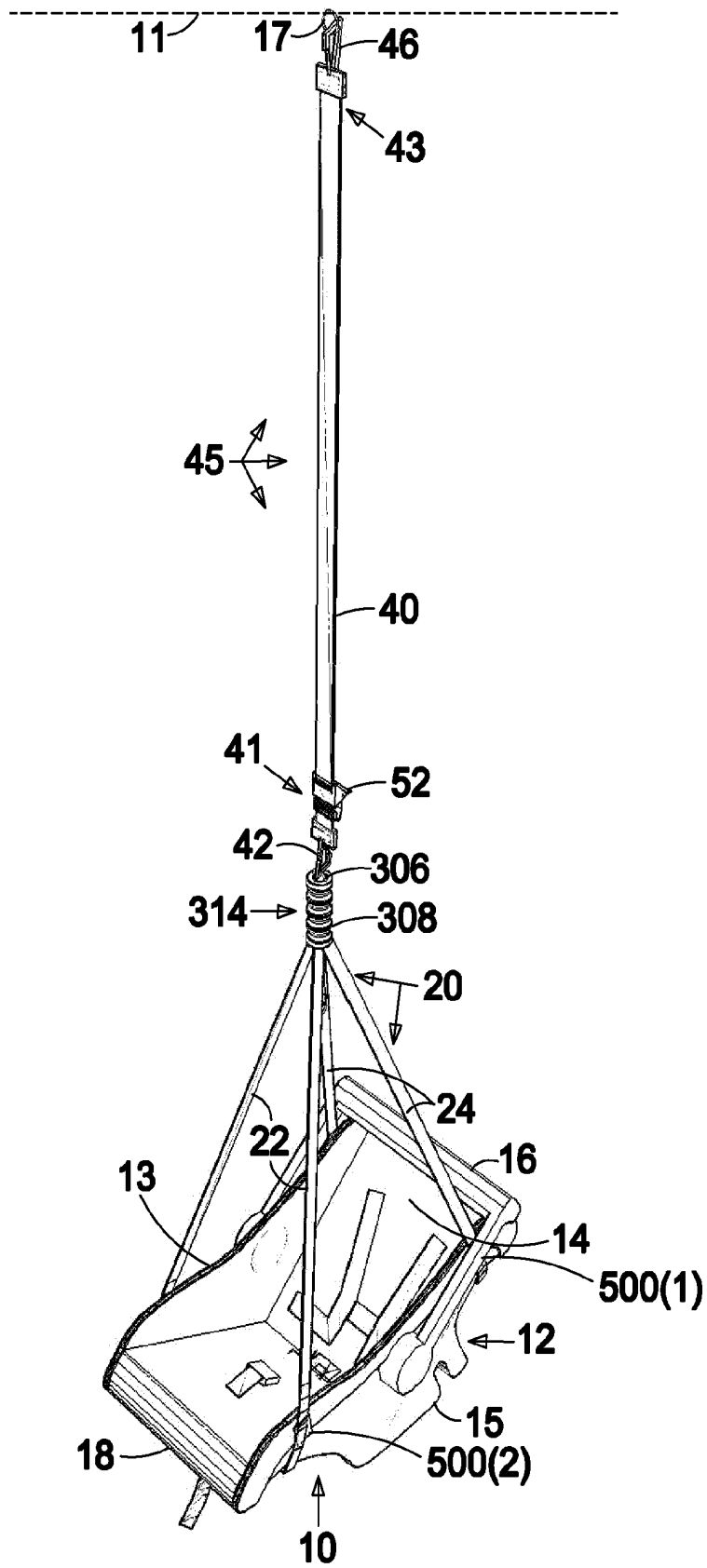
A baby seat sling suspends a baby seat from a structure. A lower strap harness extends around the rear surface of the baby seat. A lower strap suspension point extends above the seating surface of the baby seat. The lower strap suspension point comprises a junction of ends of the lower strap harness. An upper strap suspension strap is attached to the lower strap suspension point and to the structure located above the baby seat.

(22) Filed: **May 21, 2010**

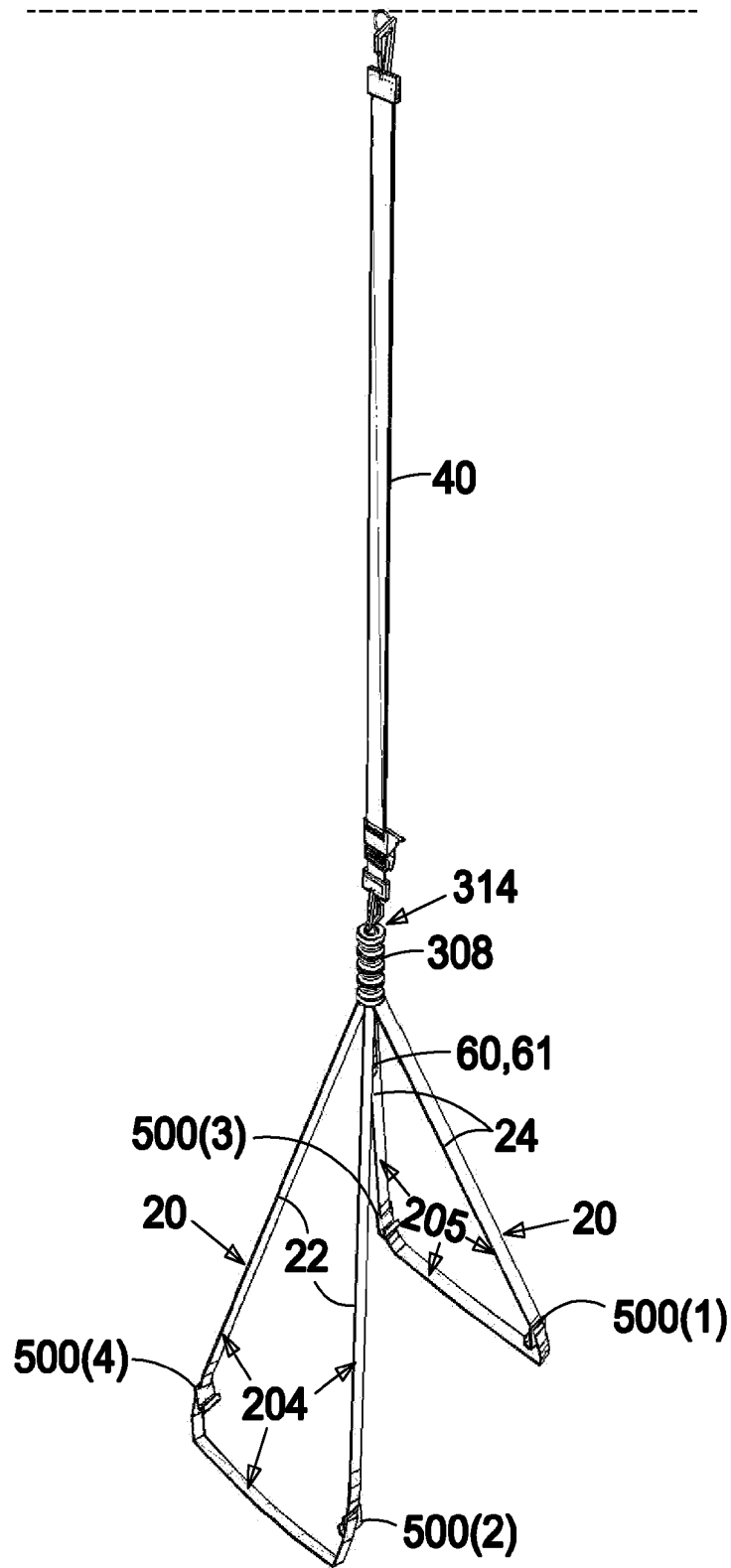
**Related U.S. Application Data**

(63) Continuation-in-part of application No. 12/384,564, filed on Apr. 7, 2009.

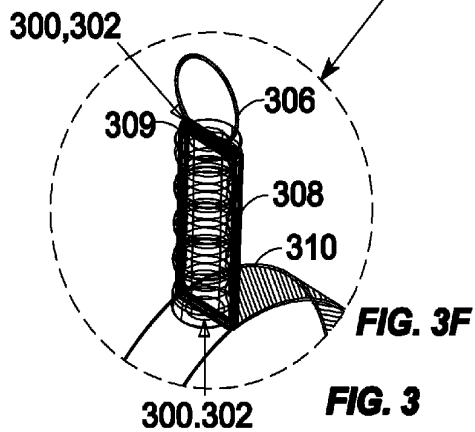
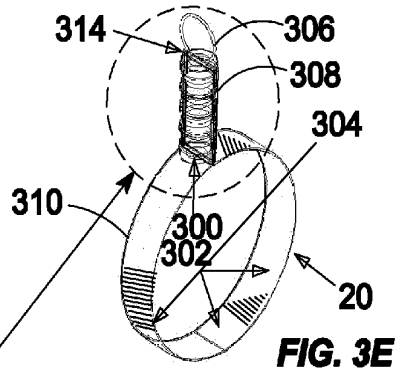
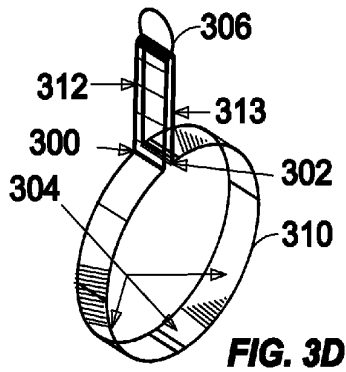
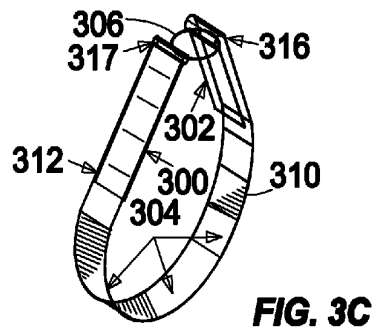
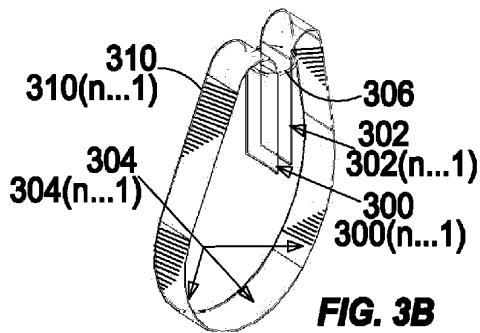
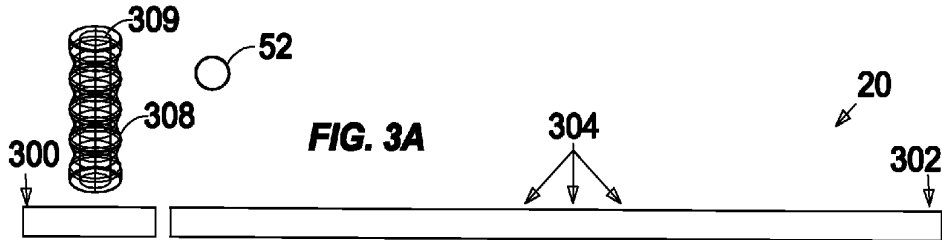




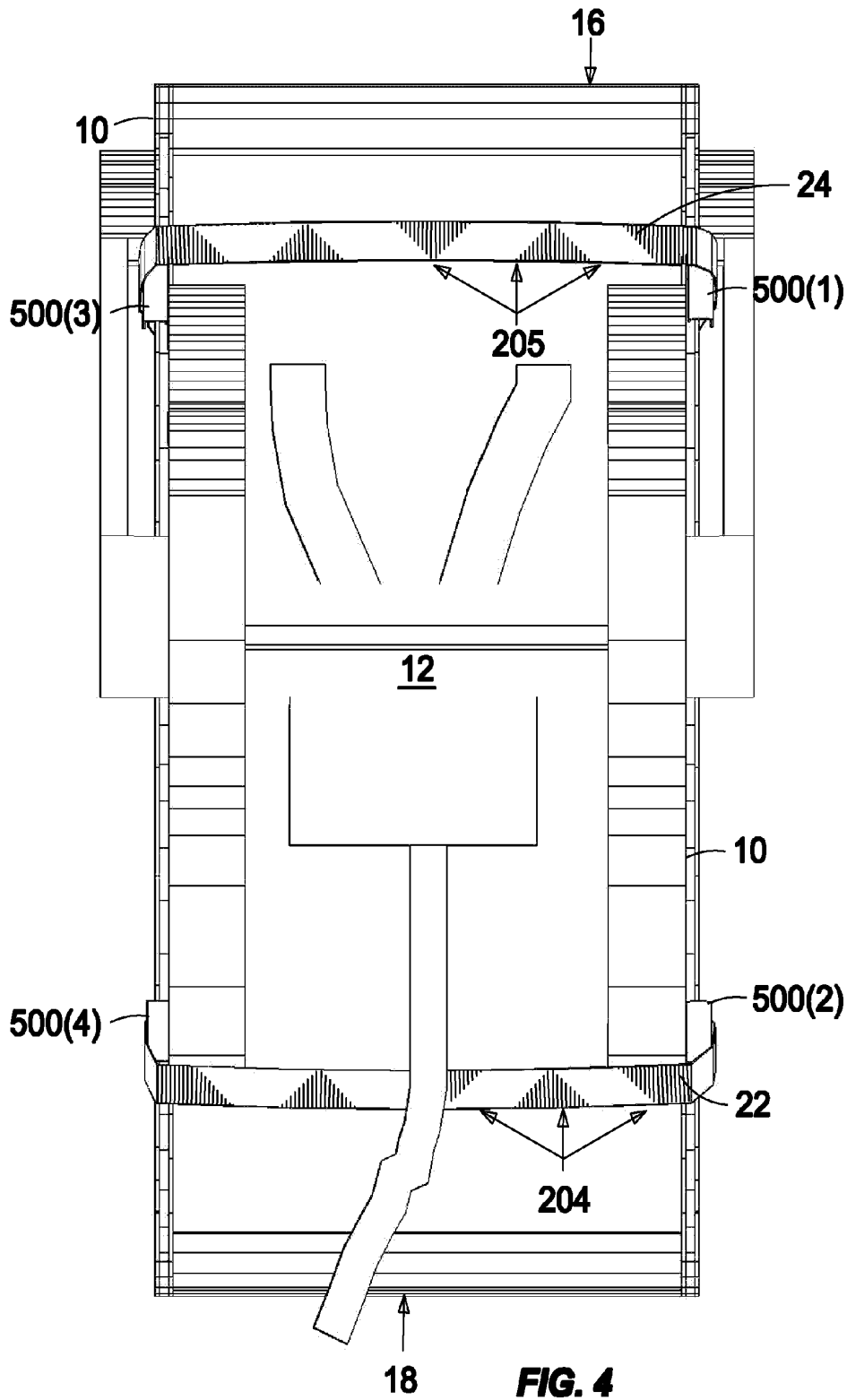
**FIG. 1**

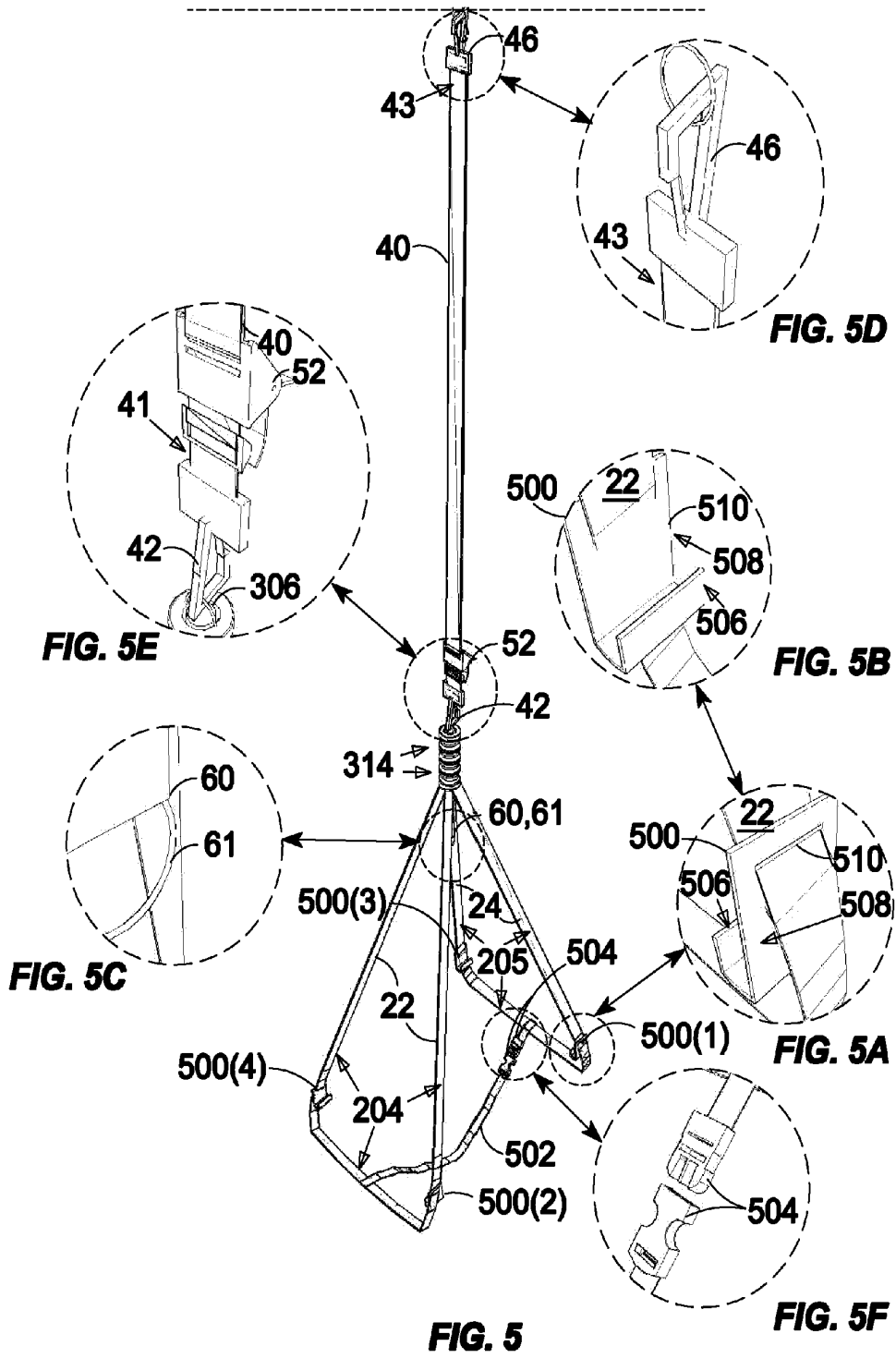


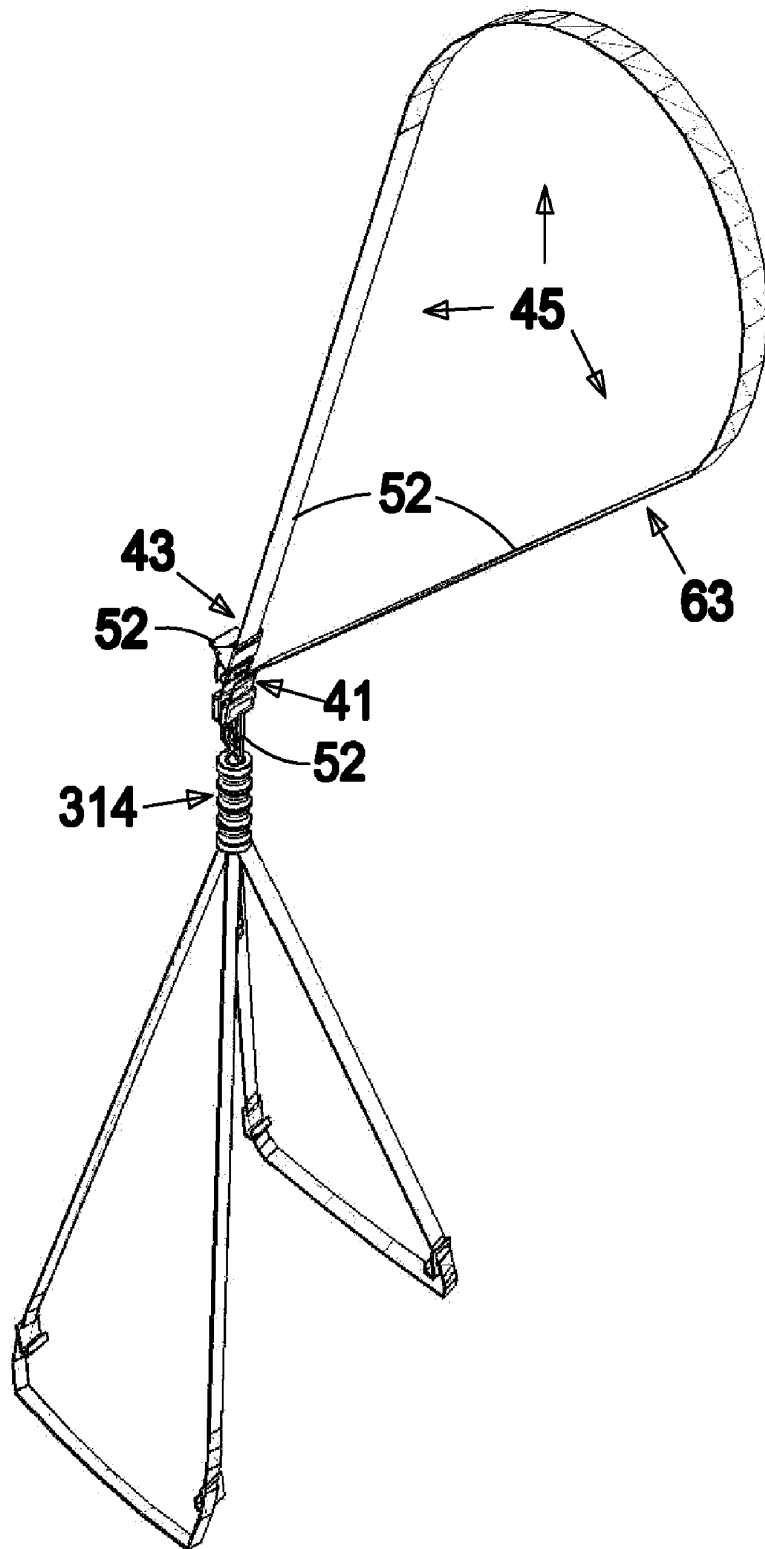
**FIG. 2**



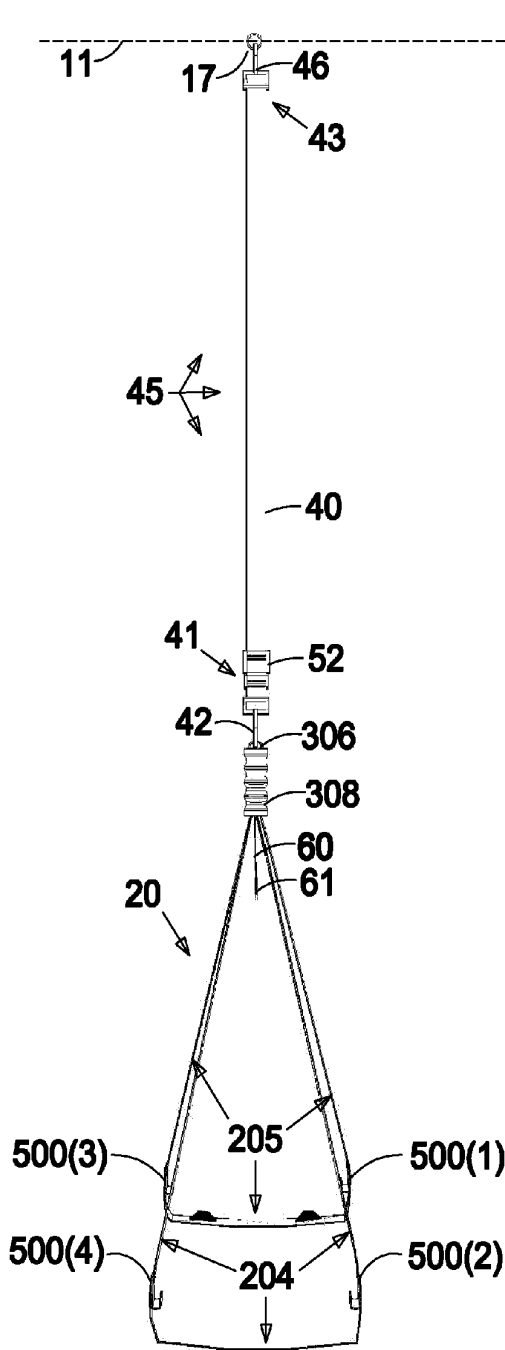
**FIG. 3**



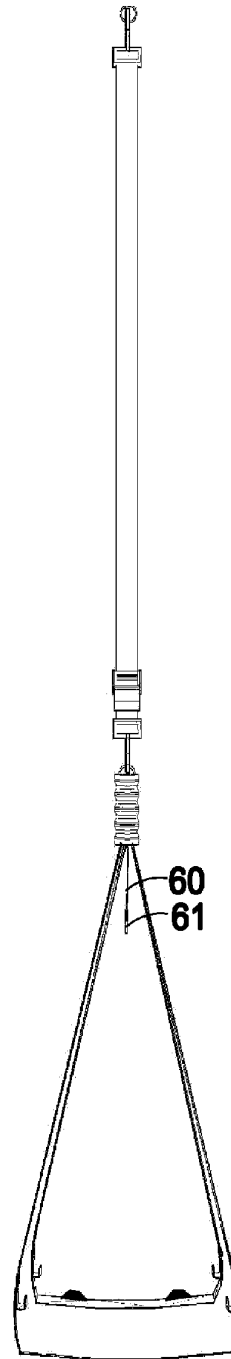




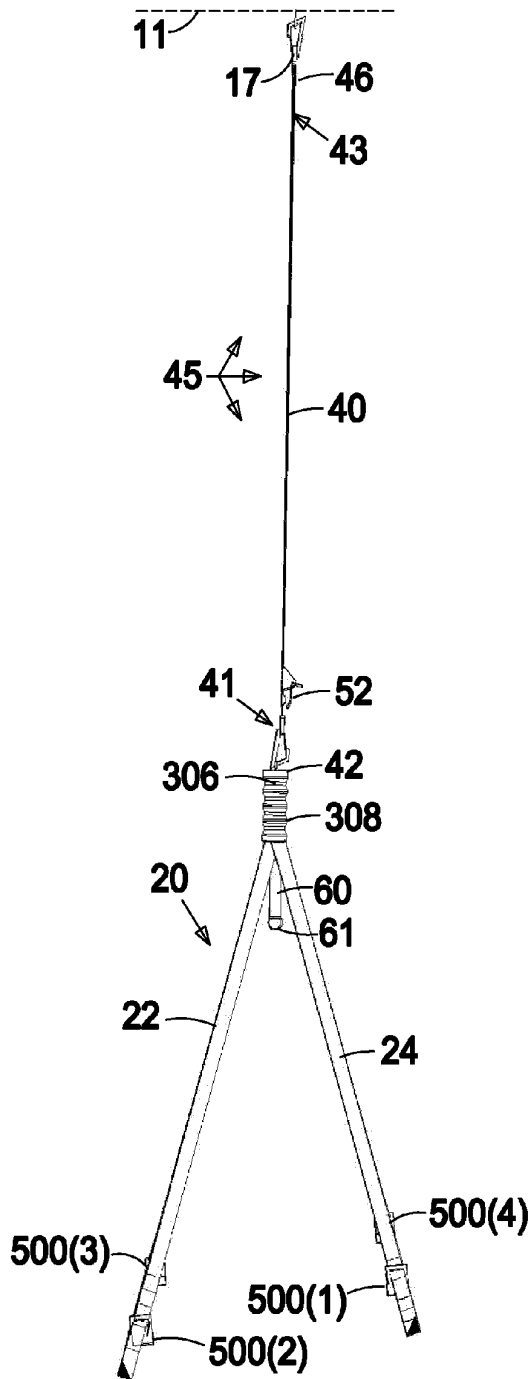
**FIG. 6**



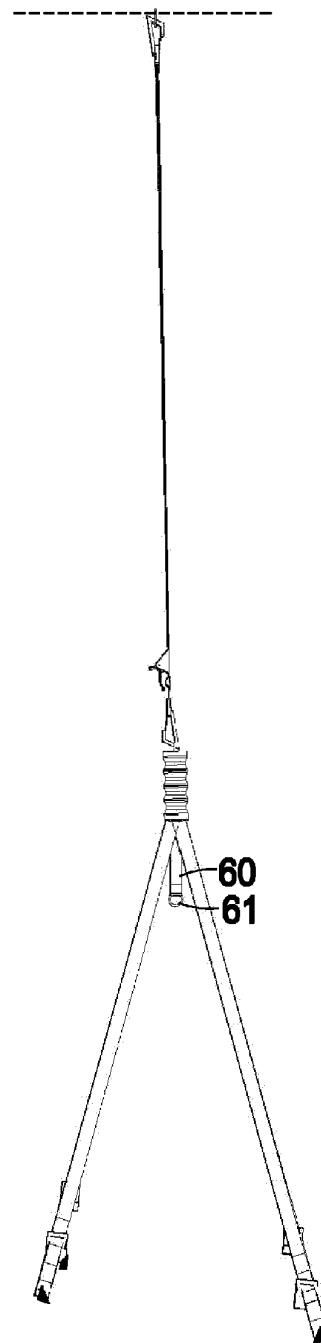
**FIG. 7**



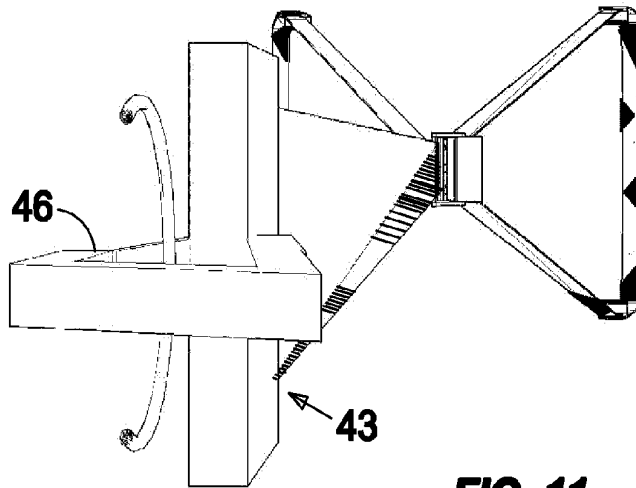
**FIG. 8**



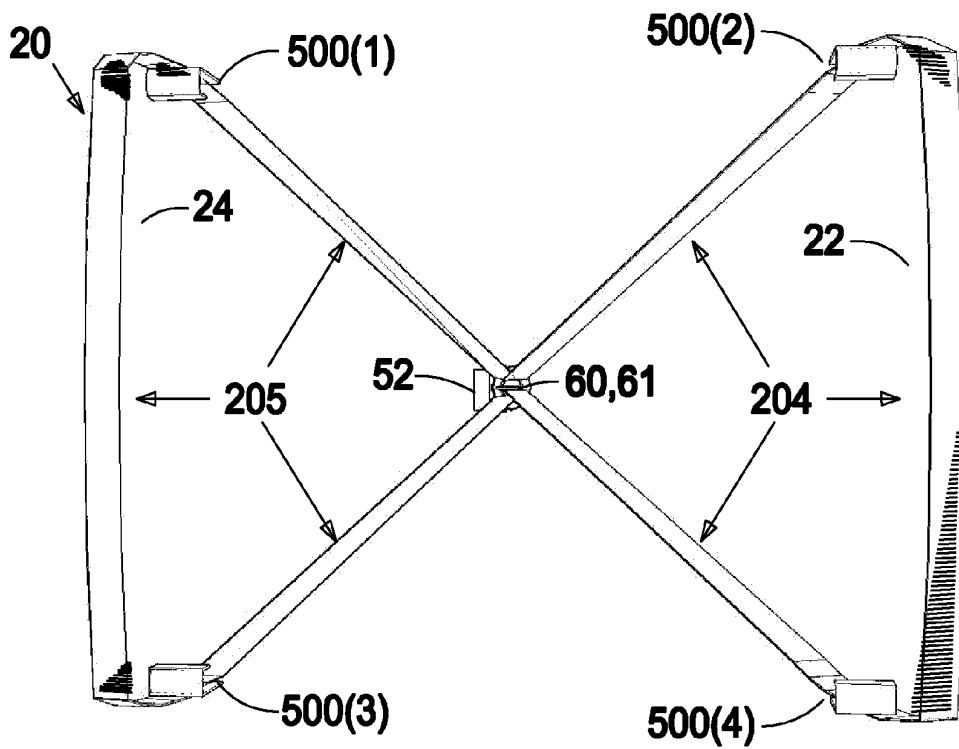
**FIG. 9**



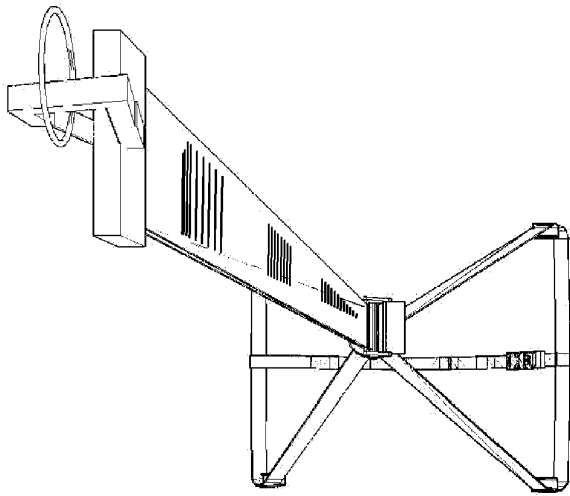
**FIG. 10**



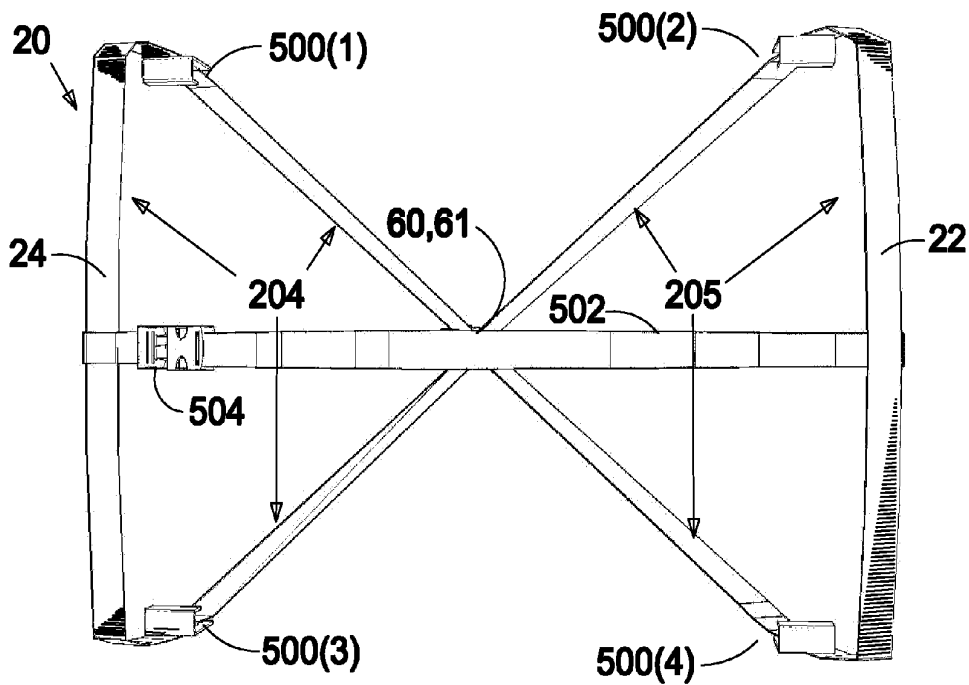
**FIG. 11**



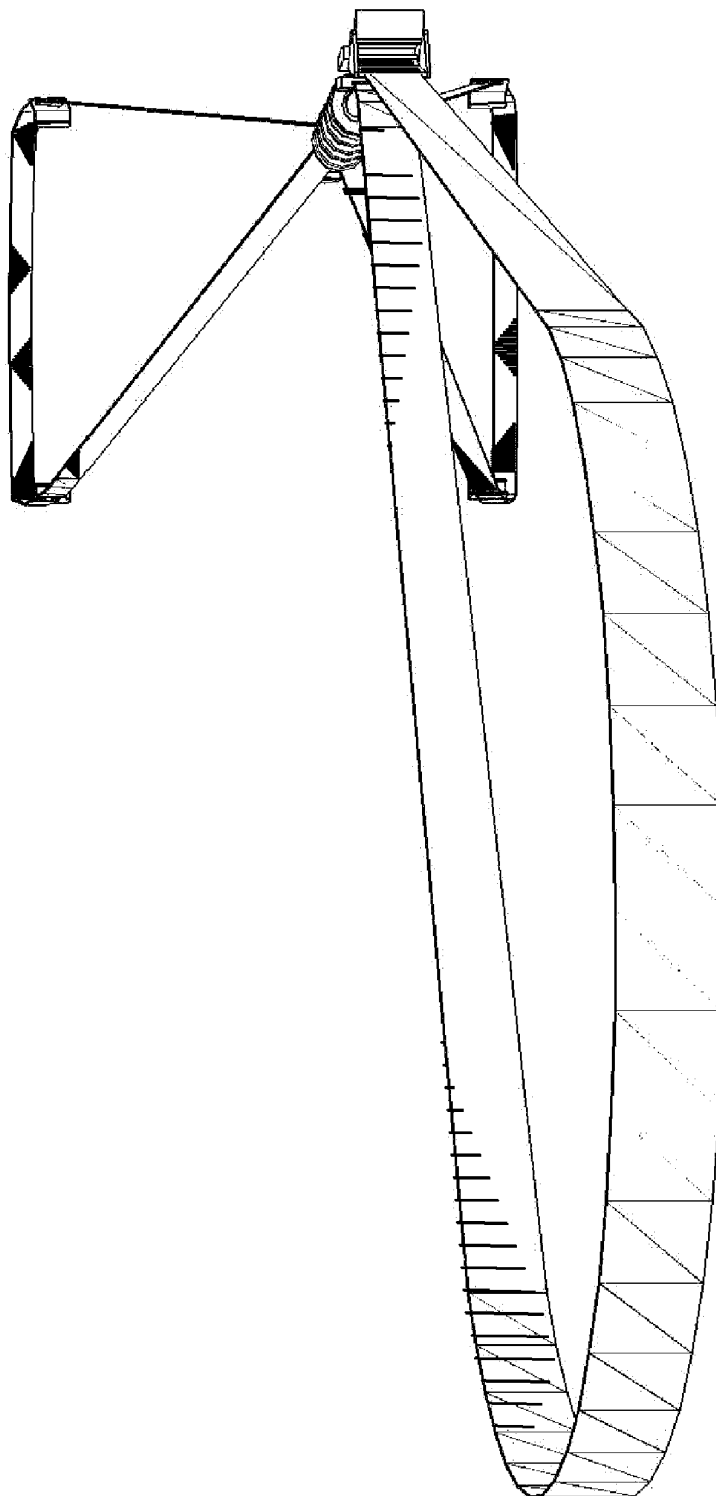
**FIG. 12**



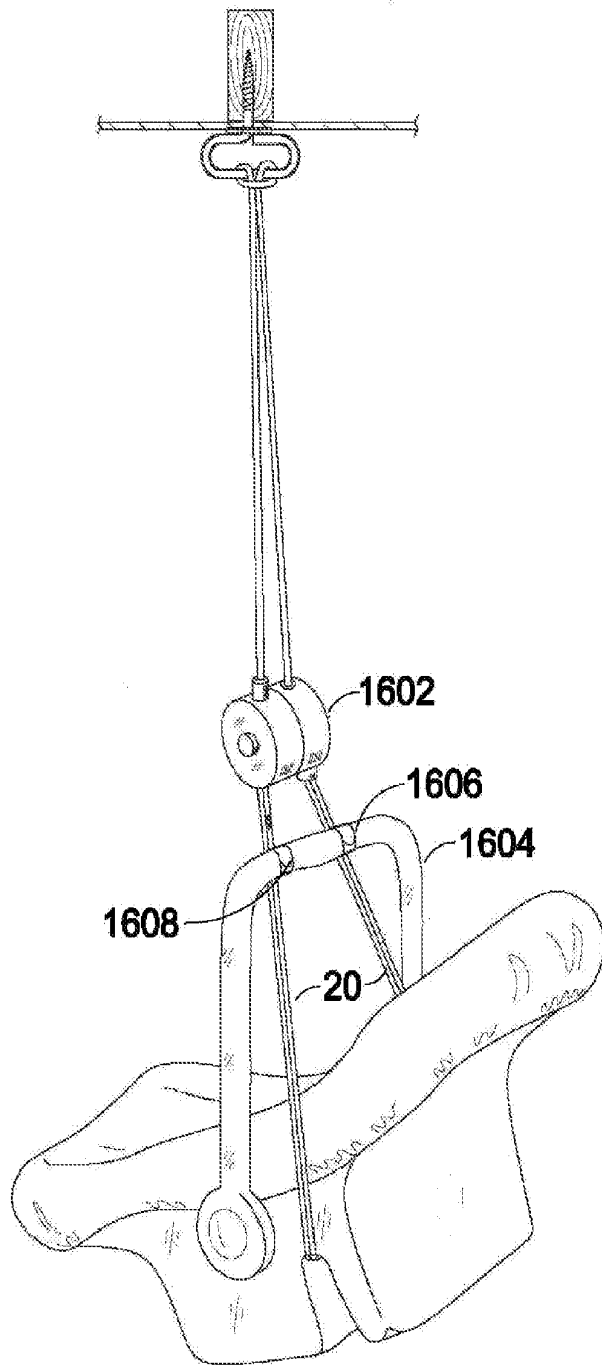
**FIG. 13**



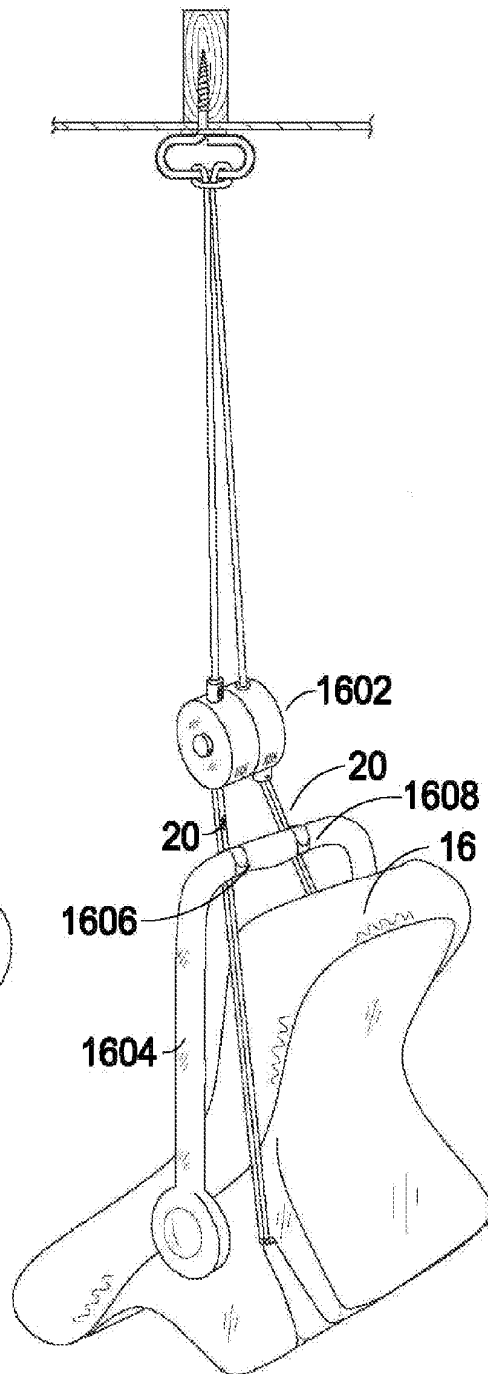
**FIG. 14**



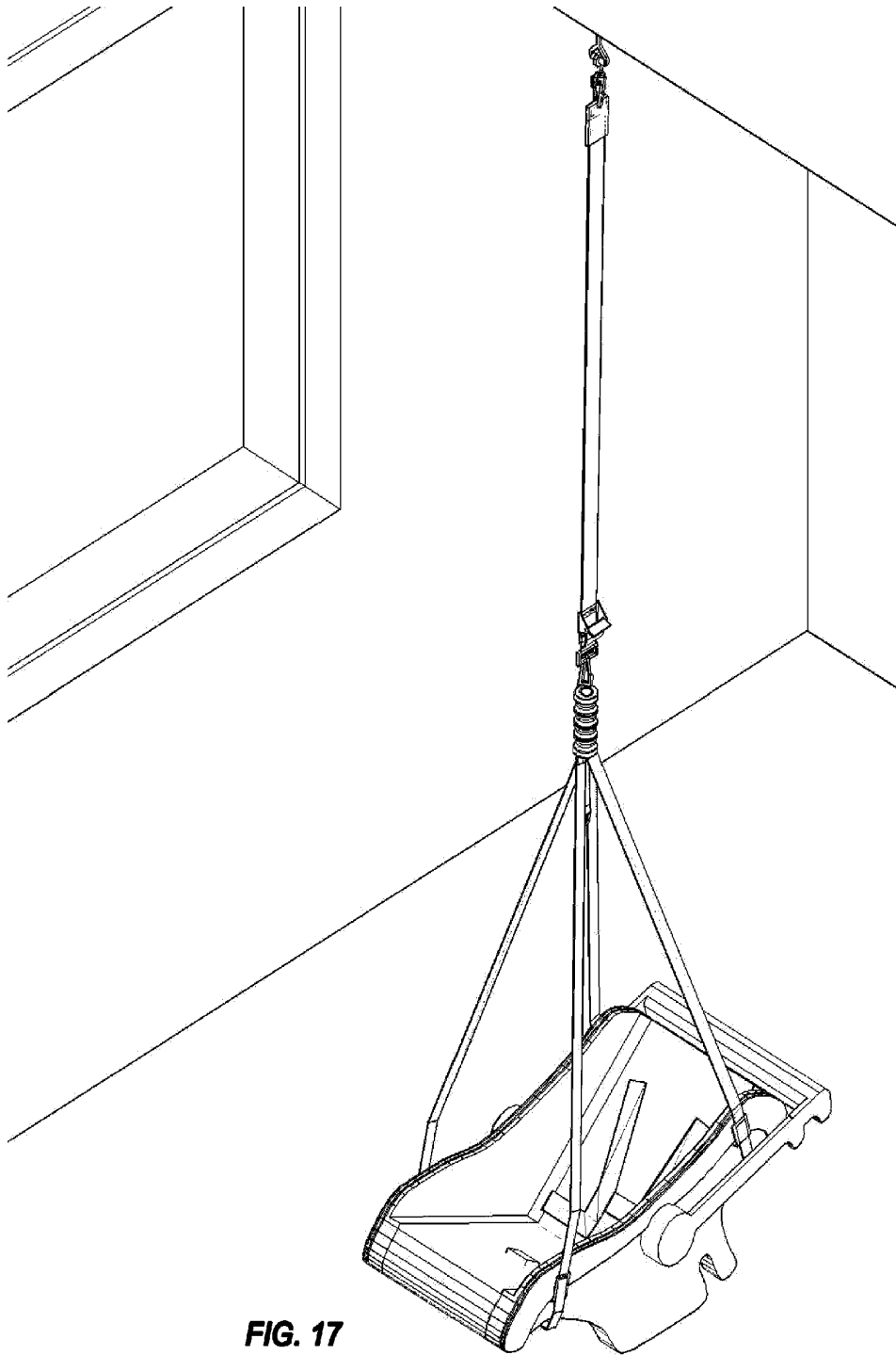
**FIG. 15**



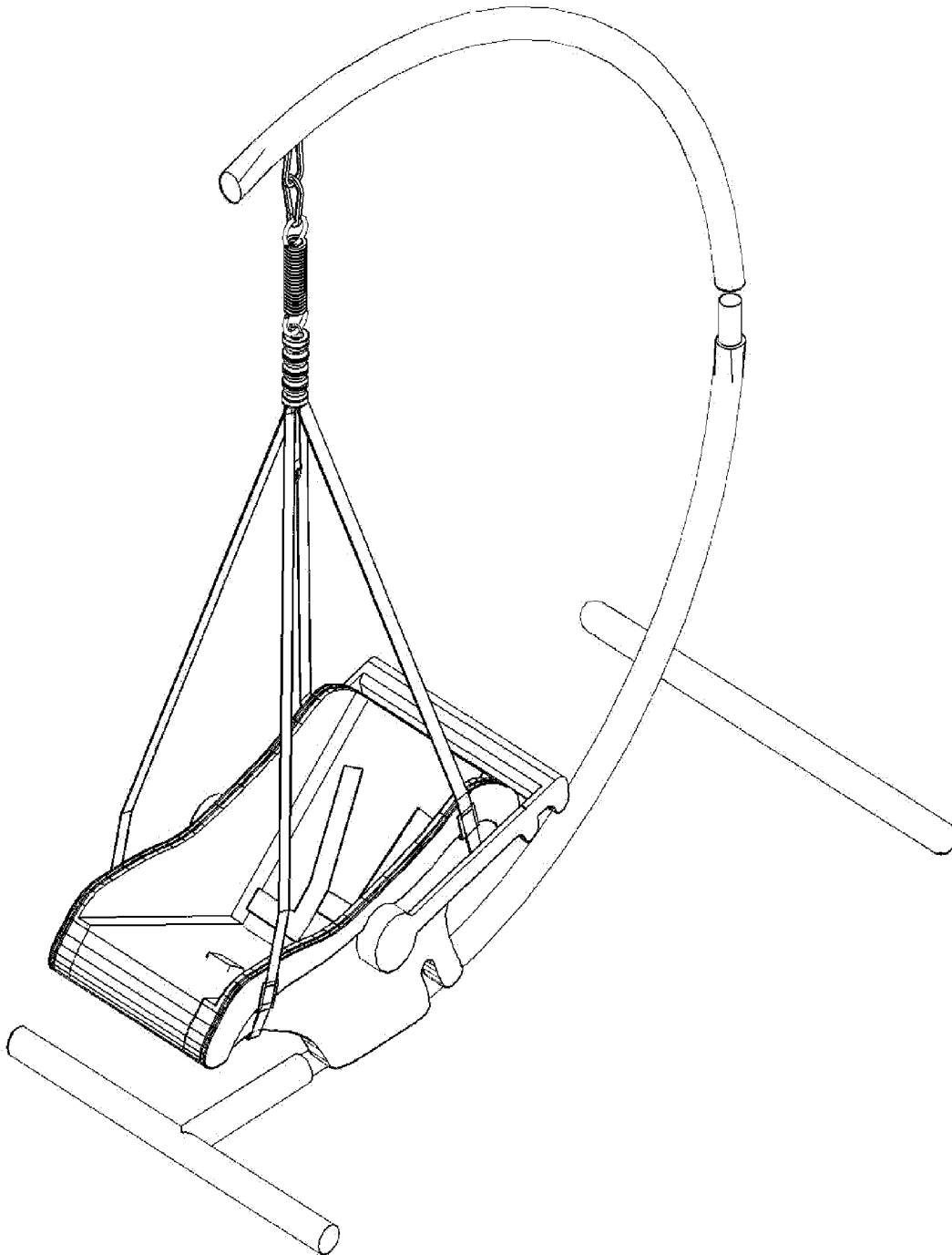
**FIG. 16A**



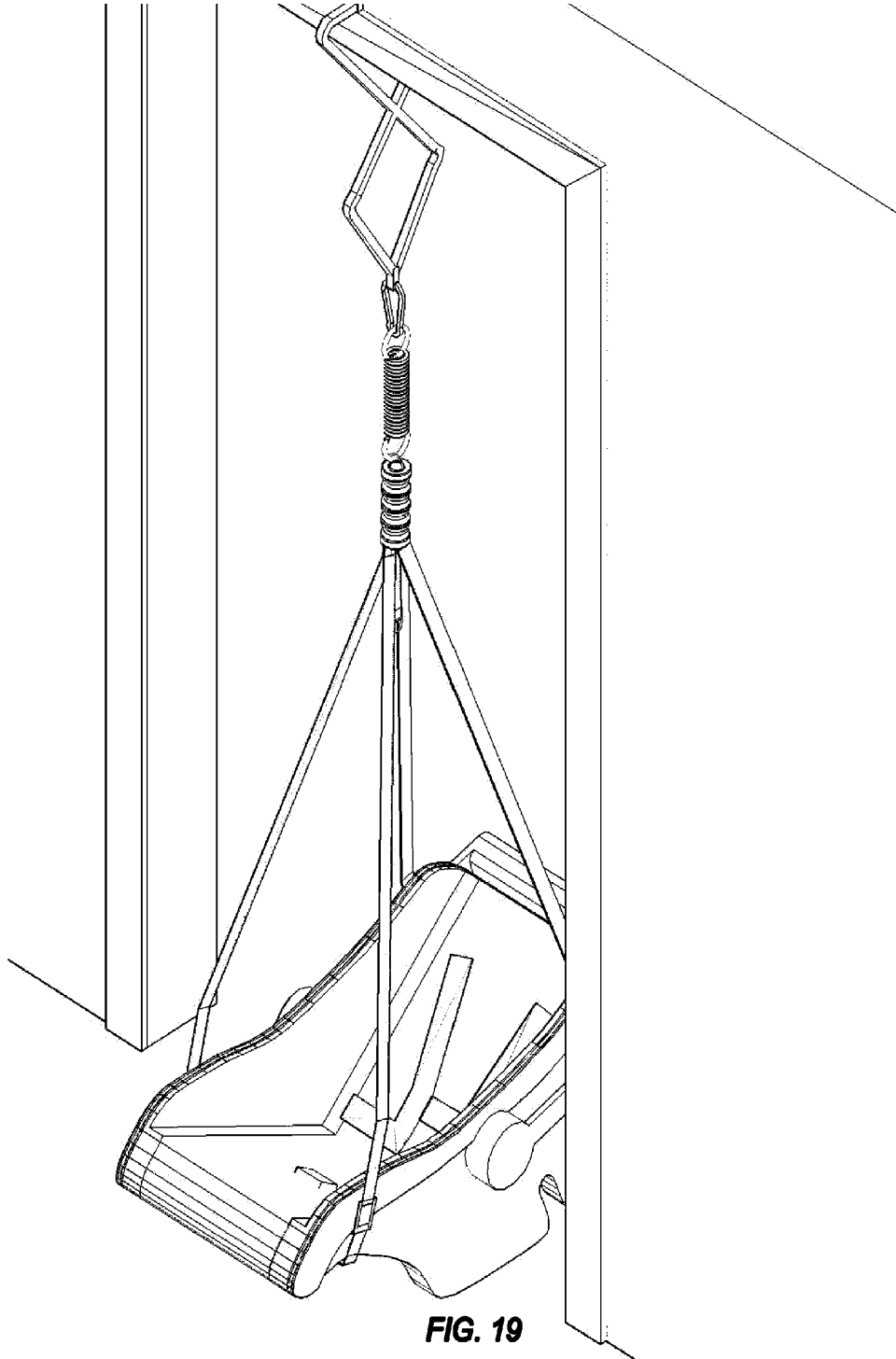
**FIG. 16B**



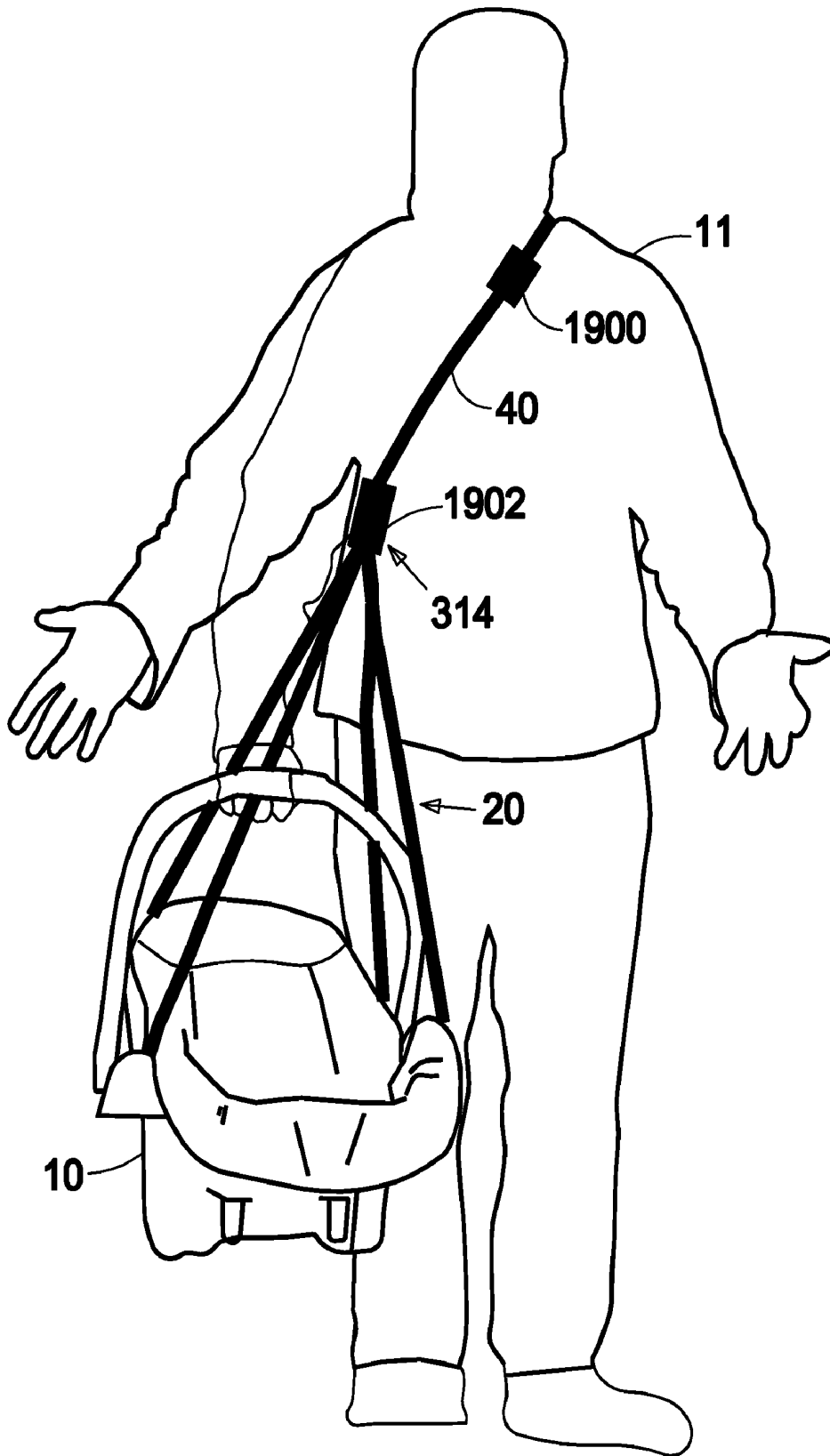
**FIG. 17**



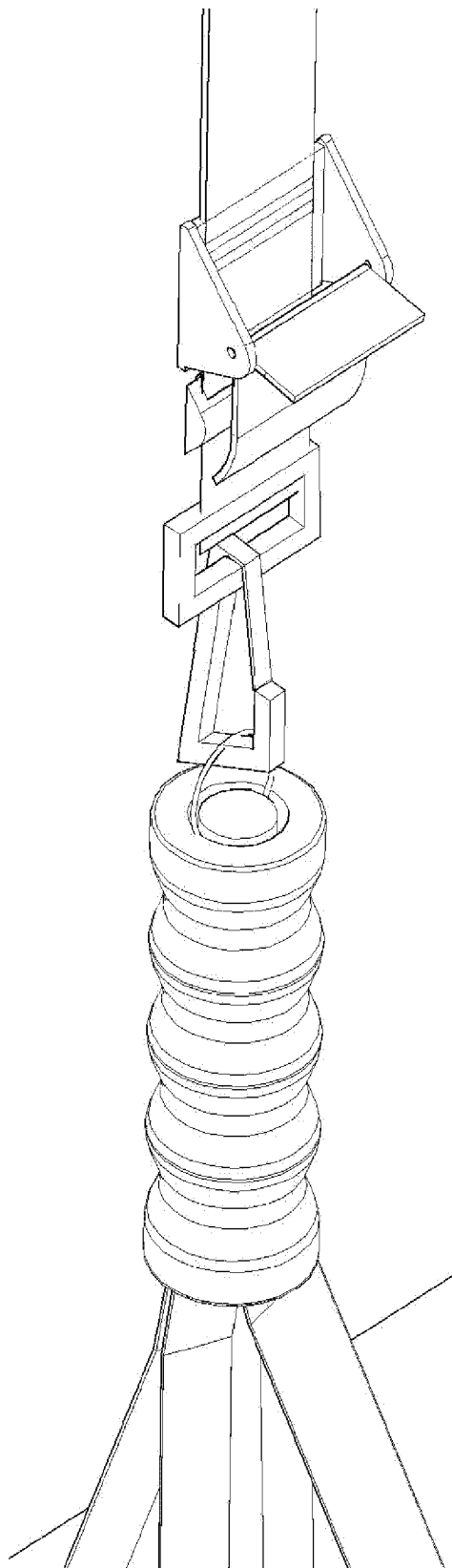
**FIG. 18**



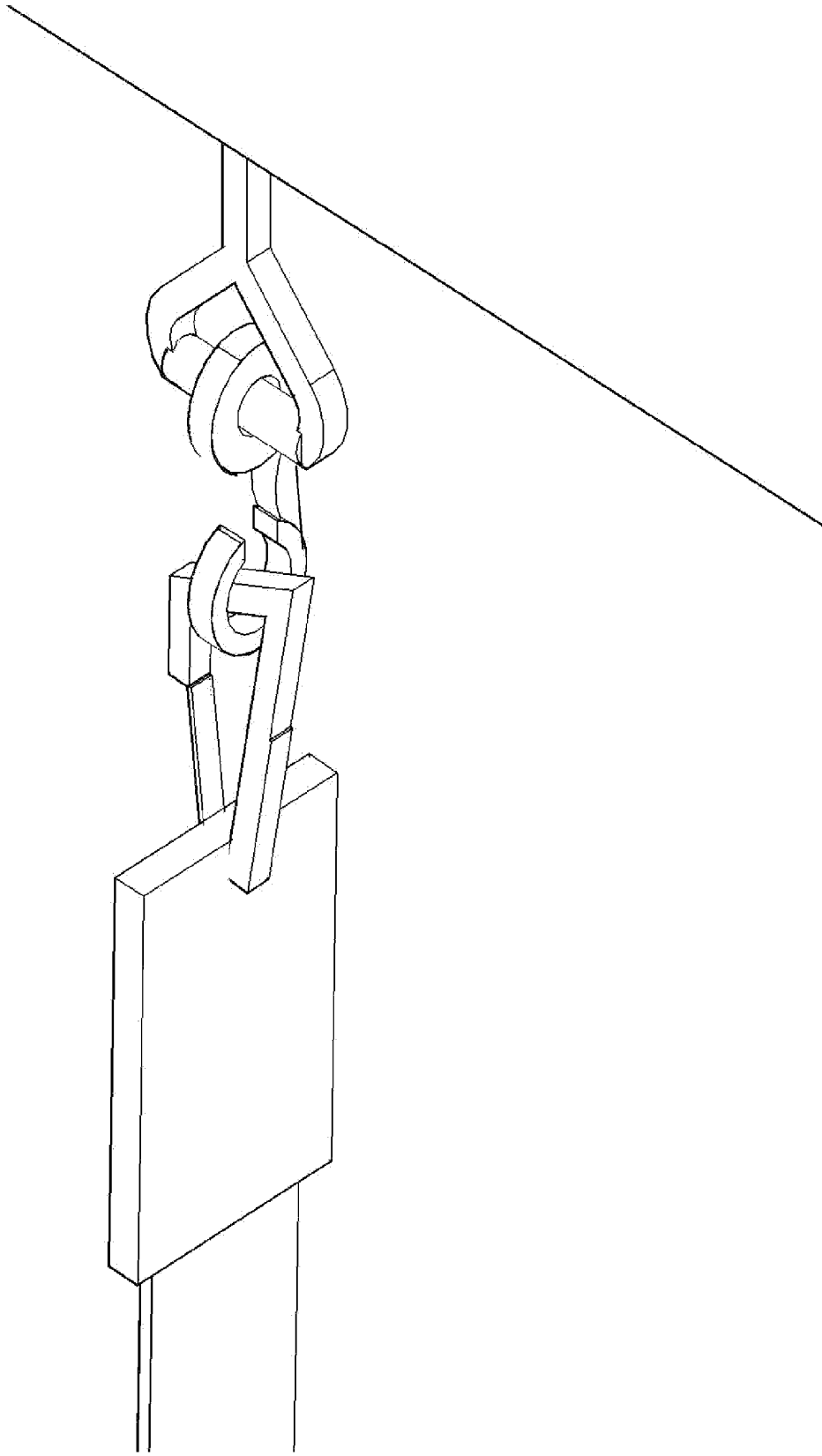
**FIG. 19**



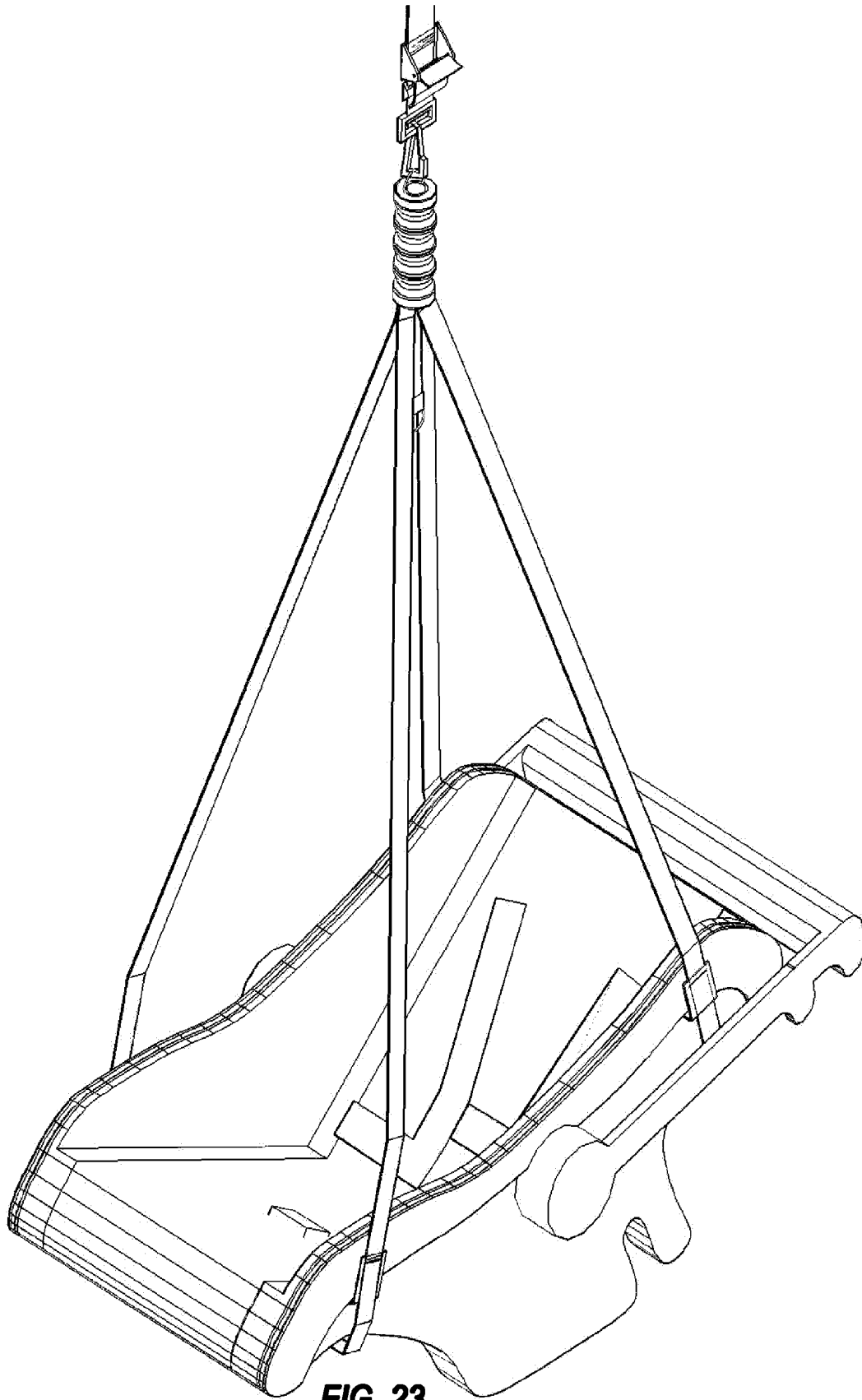
**FIG. 20**



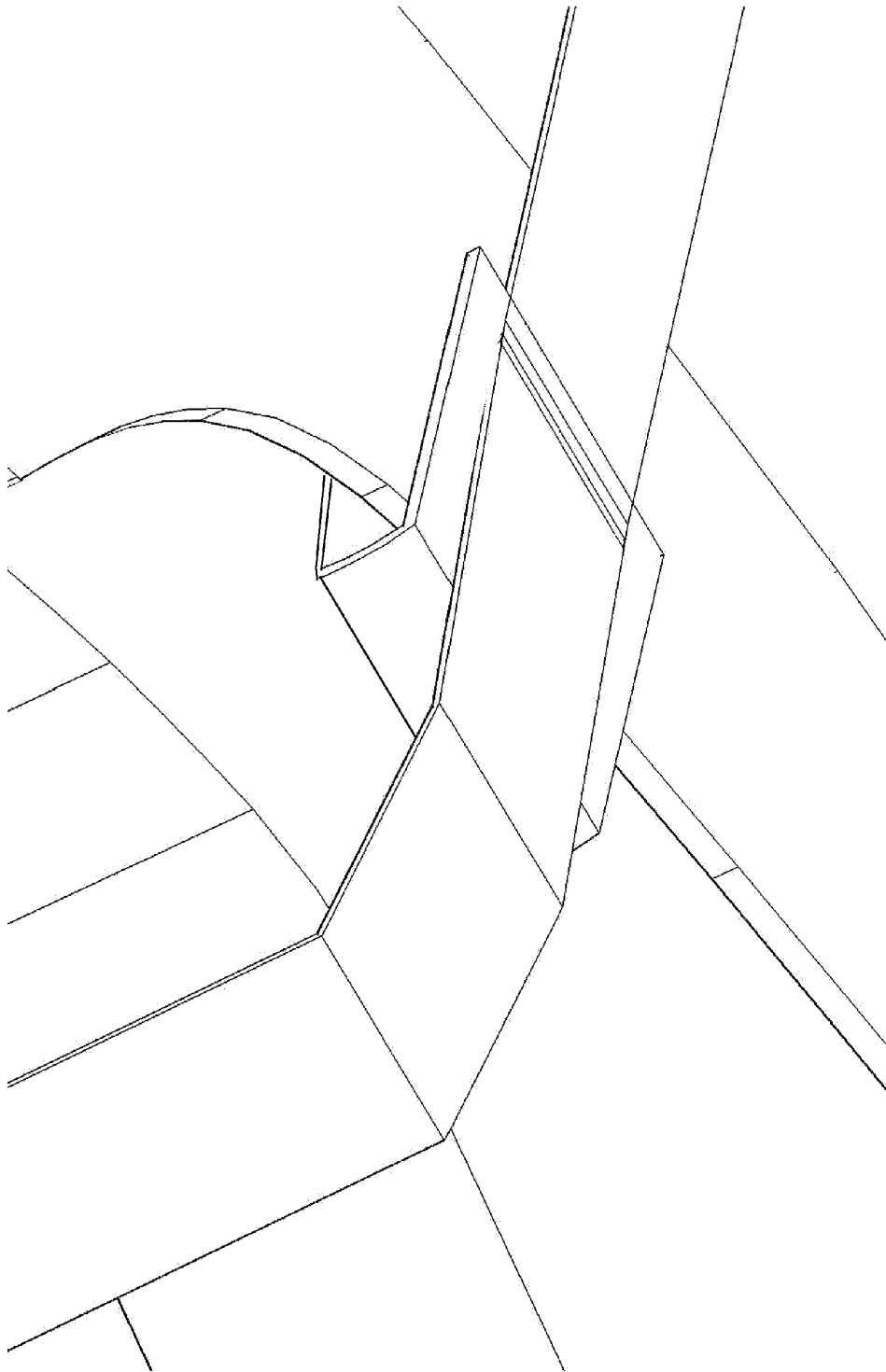
**FIG. 21**



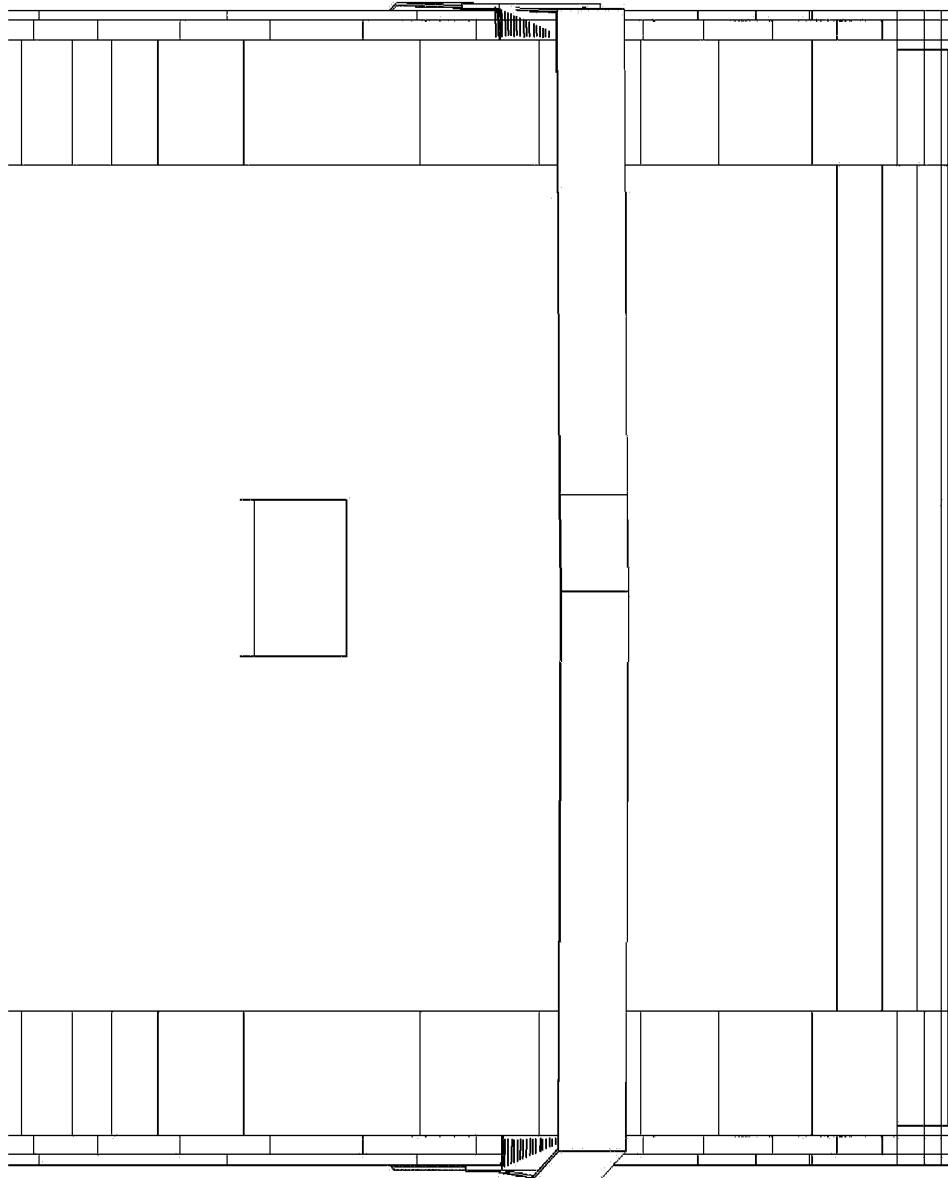
**FIG. 22**



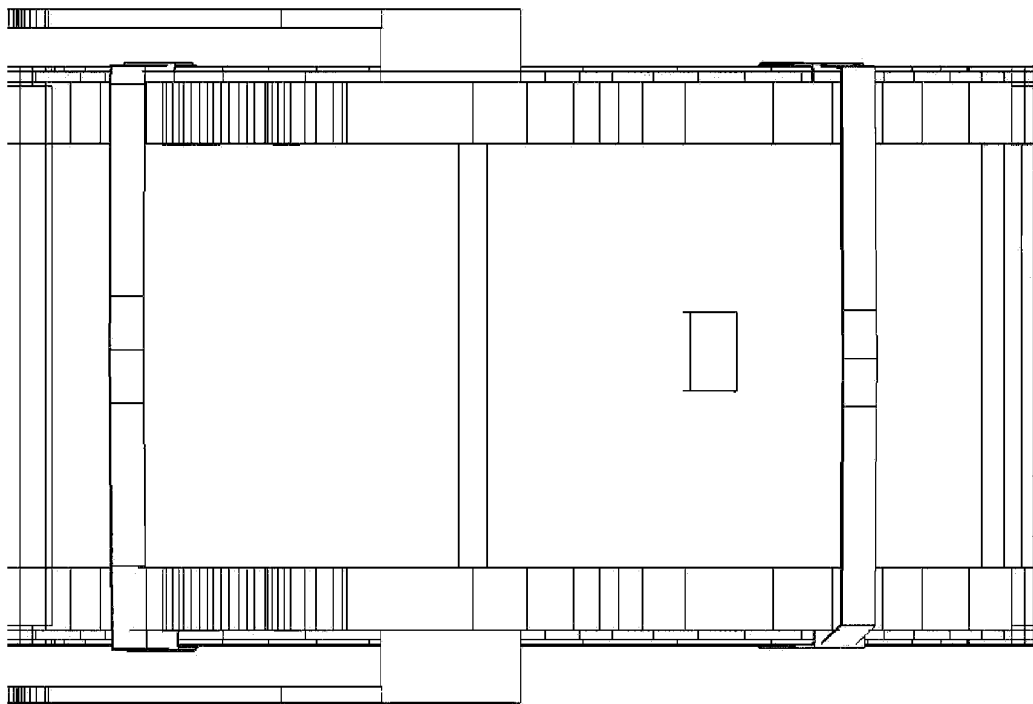
**FIG. 23**



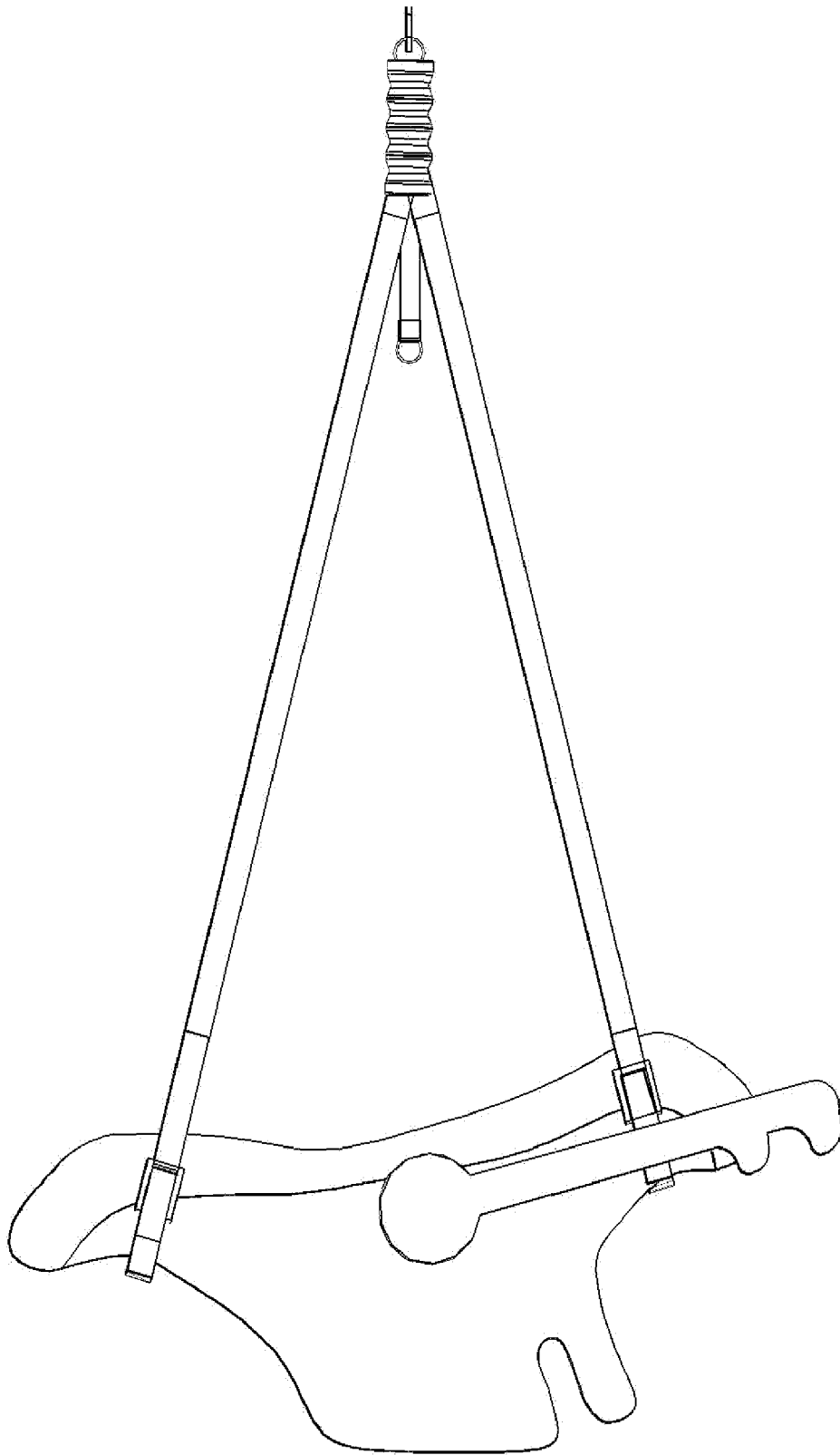
**FIG. 24**



**FIG. 25**



**FIG. 26**



**FIG. 27**

## BABY SEAT SLING FOR SUSPENDING A BABY SEAT FROM A STRUCTURE

[0001] This application is a continuation-in-part of U.S. patent application Ser. No. 12/384,564 filed Apr. 7, 2009, which claims the benefit of U.S. Provisional Application No. 61/116,006 filed Nov. 19, 2008, both of which are hereby incorporated by reference.

### BACKGROUND

[0002] Baby seats are used to support and secure a baby or small child to a seat so the baby can be safely transported in a vehicle, a stroller, carried by hand, and the like. Baby seats for these and other uses are well known and are commercially available in nearly endless designs having a huge array of configurations and options.

[0003] All baby seats for these and other uses have a rigid portion. The rigid portion has a head end where the baby's head is most closely positioned, a foot end where the baby's feet are most closely positioned, a right side, and a left side.

[0004] The rigid portion comprises a rigid shell that is contoured throughout. The rigid shell has a contoured front surface for supporting the child. Oftentimes padding is added to cover the front surface and provide a more comfortable seating area for the child. A seat belt or harness attached to the rigid shell secures the child to the front surface.

[0005] Opposite the front surface is a contoured rear surface. The rear surface is usually contoured to dock or mate with a base. Examples of a base include a car-seat base connected to the seat of a vehicle by a seat belt or connected to a stroller frame (where the baby seat is removable and the stroller frame is the base). The rear surface may be contoured with flat or supporting contours so that it is stable when placed on the ground. The front surface may also be contoured to dock or mate with a base. Other contours on the front or rear surfaces include ridges, lips, grooves, indentations, protrusions, openings, and the like. Contours such as openings may serve the function of allowing a seat belt or harness to pass through, or may be there to reduce the weight of the baby seat, or may be the result of a manufacturing requirement. Some of the contours may have a function, for example to mate with a corresponding base, and some may serve no function, at least to an end-user, such as a ridge that is the result of or required by a manufacturing process.

[0006] The rigid portion also includes rigid extensions extending from the rigid shell. One common example of a rigid extension is a carrying handle. The carrying handle, which is part of the rigid portion, is connected to the rigid shell. It is appreciated that the connection may be a moveable connection, such as a handle moveably connected so that it can pivot. It is also appreciated that the rigid shell may comprise more than one rigid section and that the rigid sections may be moveably connected to one another, such as in a baby seat wherein the angle between the head end and the foot end is adjustable. This allows the baby seat to be changed from a generally upright seating position to a generally flat lying down position. Accessories may also be attached to the rigid shell, such as umbrellas, cups, and the like.

[0007] It should be clear now that the rigid portion of the baby seat can have an infinite number of arrangements and contours and that the topography of the rigid portion depend on things such as the intended use of the baby seat, manufacturing requirements, safety regulations, and the like. Accord-

ingly, each baby seat has a topography defined at least in part by the contours that are specific to each manufacturer, and such topographies even vary among different product lines from the same manufacturer.

[0008] The designs are limitless, and a study of the multitude of baby carriers currently on the market confirms that, inasmuch as the rigid portion is concerned, almost every design is different from every other design. As a result, in general, a baby carrier designed to be used with one base or accessory cannot be used with a different base or accessory.

[0009] As mentioned above, uses of a baby seat include securely carrying a baby or setting the baby down without worrying that the baby will crawl away or get injured. For this, the baby seat may have a handle and a generally flat rear surface topography. It would be desirable if there were also a way to suspend any baby seat from a structure. For example it would be desirable to be able to hang the baby seat from a frame on the floor, or from a bar secured in a doorway, or from a tree limb, or from a hook on a ceiling, thereby converting the baby seat into a swing. In another example the structure that the baby seat is suspended from is the shoulder of a person. In such an arrangement the person can carry the baby in the baby seat in a hands-free manner. And the person can carry the baby seat for extended periods of time without fatigue since the baby seat hangs from the shoulder or torso rather than having to be actively grasped and lifted, as is the case with a handle.

[0010] Unfortunately, this is not presently possible in a universal manner. While a baby seat can be designed with specific features so that it can be suspended from above, it is not possible to take an existing car seat with an unknown or unstudied design and safely suspend it. An existing car seat or one with an unknown or unstudied design requires modifications specific to that seat in order to safely suspend it from above. And such modifications may not even be possible because modifying the design could render the car seat unsafe or unsuitable for its intended primary use.

[0011] Thus a need presently exists for a baby seat sling for suspending a baby seat—any baby seat—from a structure and to do so without having to modify the baby seat, without compromising the safety of the car seat for its intended primary use, and without having to know or understand the particular and specific design elements of the baby seat.

### SUMMARY

[0012] A baby seat sling suspends a baby seat from a structure. The baby seat has a rigid portion, a head end, a foot end, a left side, and a right side. The rigid portion comprises a rigid shell having a contoured front surface for supporting a child and a contoured rear surface opposite the seating surface. The rigid portion comprises rigid extensions extending from the rigid shell. The baby seat sling comprises a lower strap harness that extends around the rear surface of the baby seat. The lower strap harness comprises a head-end lower strap comprising a first strap end, a second strap end, and an intermediate portion. The intermediate portion is disposed on the contours of the rear surface of the head end of the baby seat. The lower strap harness further comprises a foot-end lower strap comprising a first strap end, a second strap end, and an intermediate portion. The intermediate portion is disposed on the contours of the rear surface of the foot end of the baby seat. The baby seat sling further comprises a lower strap suspension point extends above the seating surface of the baby seat. The lower strap suspension point comprises a junction of the first end and the second end of the head-end

lower strap and the first end and the second end of the foot-end lower strap. Additionally, the baby seat sling comprises an upper suspension strap attached to the lower strap suspension point and to the structure located above the baby seat. The upper suspension strap comprises an upper strap first end, an upper strap second end, and an upper strap intermediate portion.

#### BRIEF DESCRIPTION OF THE DRAWINGS

[0013] FIG. 1 shows a perspective view of a baby seat sling with an exemplary baby seat.

[0014] FIG. 2 shows a perspective view of a baby seat sling without an exemplary baby seat.

[0015] FIGS. 3A-F show the components of and a method of making a lower strap harness and a lower strap suspension point.

[0016] FIG. 4 is a bottom plan view of the baby seat sling with the exemplary baby seat shown in FIG. 1.

[0017] FIG. 5 shows another perspective view of a baby seat sling.

[0018] FIGS. 5A-F show additional details of the baby seat sling of FIG. 5.

[0019] FIG. 6 shows a perspective view of a baby seat sling for suspending a baby seat from a person.

[0020] FIG. 7 shows a front, or foot end, elevation view of a baby seat sling.

[0021] FIG. 8 shows a rear, or head end, elevation view of a baby seat sling.

[0022] FIG. 9 shows a left side elevation view of a baby seat sling.

[0023] FIG. 10 shows a right side elevation view of a baby seat sling.

[0024] FIG. 11 shows a top perspective view of a baby seat sling.

[0025] FIG. 12 shows a bottom plan view of a baby seat sling.

[0026] FIG. 13 shows a top perspective view a baby seat sling with a transverse strap.

[0027] FIG. 14 shows a bottom plan view of a baby seat sling with a transverse strap.

[0028] FIG. 15 shows a top perspective view of a baby seat sling for suspending a baby seat from a person.

[0029] FIG. 16A shows a perspective view of a baby seat sling in a first position with a lower strap extending in front of a rigid extension carrying handle.

[0030] FIG. 16B shows a perspective view of a baby seat sling in a second position with a lower strap extending in front of a rigid extension carrying handle.

[0031] FIG. 17 illustrates a baby seat suspended from a hook on a ceiling.

[0032] FIG. 18 illustrates a baby seat suspended from a frame placed on the ground.

[0033] FIG. 19 illustrates a baby seat suspended from a generally horizontal member such as a door frame.

[0034] FIG. 20 illustrates a baby seat suspended from a person.

[0035] FIG. 21 shows an upper suspension strap attached to a lower strap suspension point and the lower strap extending through a channel in a handle.

[0036] FIG. 22 shows an upper suspension strap attached to a structure above the baby seat.

[0037] FIG. 23 show a baby seat sling having a lower strap harness, a lower strap suspension point, and an upper suspension strap suspending a baby seat.

[0038] FIG. 24 shows a clip with the lower strap harness extending through an opening in the clip and a curved end of the clip disposed on the rigid portion of the baby seat.

[0039] FIG. 25 shows a head-end lower strap disposed on contours of the rear surface of the baby seat, and clips disposed on the rigid portion of the baby seat.

[0040] FIG. 26 shows a head-end lower strap and a foot-end lower strap disposed on the contours of the rear surface of baby seat.

[0041] FIG. 27 shows a left side view of a lower strap harness extending around the baby seat with the head-end lower strap comprising a clip which is disposed in a left-side contour of the baby seat, and an accessory strap connected to the lower strap suspension point.

#### DETAILED DESCRIPTION

[0042] FIG. 1 shows a perspective view of a baby seat sling with an exemplary baby seat. The baby seat 10 is suspended from a structure which is symbolically represented by dotted line 11. The exemplary baby seat 10 is shown for illustrative purposes only. FIG. 2 shows a different perspective view of a baby seat sling without the exemplary baby seat.

[0043] A lower strap harness 20 extends around the rear surface 12 of the baby seat 10. The lower strap harness 20 comprises a head-end lower strap 24 and a foot end lower strap 22. The baby seat has a head end 16, a foot end, 18, a right side 13, and a left side 15. Only the rigid portion of the exemplary baby seat 10 is illustrated but it is understood that the baby seat may comprise additional elements.

[0044] FIGS. 3A-F show the components of and a method of making a lower strap suspension point 314 and the lower strap harness 20. The lower strap suspension point 314 extends above the seating surface 14 of the baby seat 10 and comprises a junction of the ends (300, 302) of the head-end lower strap (24, 310) and the foot end lower strap (22, 300). The lower strap suspension point provides a means for connecting opposing sections of the strap(s) together at an area above the front surface of the baby seat. The lower strap suspension point 314 further provides a means for connecting additional elements to the lower strap harness 20, as will be disclosed below.

[0045] The lower strap harness 20 comprises at least one strap 310. The strap has a first strap end 300, a second strap end, and an intermediate portion 304. Straps are well known by those having ordinary skill in the art. The strap is long and generally flat, and may be variable in length. The strap could alternatively be generally tubular like a rope. By "long" it is meant that the strap has a length such that when the intermediate portion 304 of the strap is approximately centered on the bottom of the baby seat and the two ends 300, 302 are extended around the sides of the baby seat, the two ends come together at a point at least one foot above the baby seat. In one example the strap is a nylon webbing, has a length of at least 13 feet, a width of 1 inch, and a thickness of around 0.04 of an inch. Nylon webbings like this are extremely strong, typically able to withstand tensions of thousands of pounds. The strap may comprise other materials, alone and in combination, such as cotton, polypropylene, and polyester.

[0046] As shown in FIG. 3A, the lower strap harness also includes a ring such as a metal ring 306. The lower strap harness comprises at least one strap 310. The lower strap harness 20 of FIG. 1 comprises two straps. For simplicity of illustration, FIG. 3 shows how to make a lower strap harness with one strap, but a lower strap harness with multiple straps

can be made in exactly the same manner as shown and described for a single strap. This is illustrated in FIG. 3B where the strap(s) is/(are) labeled **310(1 . . . n)**, strap ends **300(1 . . . n)** and **302(1 . . . n)**, and intermediate section(s) **304(1 . . . n)**. For multiple straps, the method described below is carried out for each strap **310(1 . . . n)**.

[0047] So, in FIG. 3B the ends **300, 302** are passed through the ring **306** (or in the case of multiple straps **310(1 . . . n)**, the ends **300, 302** of each strap **310(1 . . . n)** are passed through the ring **306**).

[0048] Next, as shown in FIG. 3C, each strap end **300, 302** is connected to the ring **306**. Specifically, the first end **300** is connected **312** onto itself to form loop **317**. In the illustration, the second end **302** has been folded back onto itself but has not yet been connected to itself in order to illustrate an intermediate step of the method. In FIG. 3D the second end **302** is connected **313** to itself thereby forming loop **316** that connects the second end **302** looped connection with the ring **306**. FIG. 3D illustrates the strap **310** with both ends connected (**312, 313**) to the ring **306**. If there are additional straps **310(1 . . . n)** then each end of each strap is folded back onto and connected to itself in the same manner, thereby connecting both ends of every strap **310(1 . . . n)** to the ring **306**. The strap ends may be connected (**312, 313**) by sewing them together or by any other means.

[0049] Next, the strap ends (**300, 302**) are connected to each other. If there is more than one strap **310(1 . . . n)** then all strap ends are connected together. The strap ends (**300, 302**) may be connected by sewing them together.

[0050] FIGS. 3E and 3F show another way of connecting the straps ends to one another. The intermediate section **304** (or, for more than one strap, the intermediate sections **304(1 . . . n)**) are passed through a channel **309** (FIGS. 3A, 3E, 3F) in a handle **308** (FIGS. 3A, 3E, 3F). The handle **308** is advanced towards the ring **306** thereby joining opposing section of the strap(s) (**300, 302**) above the front surface of the baby seat **14**. Advancing the handle **308** snugly toward the ring further cinches the strap(s) together and to the ring **306** to reinforce a strong junction **314**. The handle **308** shows only one exemplary design which has an interior channel **309**. It is appreciated that other designs are possible. For example, the handle may have an opening or slit extending from the interior channel through to the exterior of the handle thereby forming an lengthwise end-to-end slit or opening into which the straps can be guided through the side of the handle to the interior channel.

[0051] In addition to connecting opposing sections of the strap **310** together, the ring **306** provides a connection point for clasps, ropes, straps, hooks, and the like. It is noted that FIG. 3 shows only one method of building a lower strap harness and that there are many other ways to build the harness with many types of materials. For example, a harness can be built following all of the steps detailed above but without a metal ring. Instead, one or more of the loops (**316, 317**, FIG. 3C) formed by the strap **20** provide the connection point. Or the ends (**300, 302**) can be sewn together and a hook, clasp, buckle, eyelet, or retractable reel (**1602** of FIGS. 16A-B) attached to the connected ends. These and other modifications can be made alone and in combination.

[0052] One other modification includes an accessory attachment strap **60** that is connected, for example sewn, to the lower strap suspension point **314**. The accessory attachment strap **60** is for attaching accessories to the lower strap suspension point. The accessory attachment strap **60** extends

generally towards the seating surface **14** of the baby seat **10**. An exemplary accessory attachment strap **60** is shown in FIGS. 2, 5, 7, 8, 9, 10, and 12 and includes a short strap **60** with a connector **61** such as a ring, clasp, or hook attached to the strap's free end (the end not sewn to the lower strap suspension point **314**). Accessories such as toys, ornaments, and the like may be attached to the connector so that they hang within sight or reach of a baby in the baby seat.

[0053] FIG. 4 is a bottom plan view of the baby seat sling with the exemplary baby seat shown in FIG. 1. Referring to FIGS. 1-4, the lower strap harness **20** comprises the head-end lower strap **24** and the foot-end lower strap **22**. The lower strap suspension point **314** extends above the seating surface **14** of the baby seat **10** and comprises the junction of the ends of the head-end lower strap **24** and the foot end lower strap **22**. The junction of the ends are not visible in FIGS. 1 and 2 due to obstruction by the handle **308**, but the junction was disclosed in detail in FIG. 3.

[0054] The lower strap suspension point provides a means for connecting opposing sections of the strap (**22, 24**) together at an area above the front surface **14**, of the baby seat **10**. The lower strap suspension point **314** further provides a means for connecting additional elements to the lower strap harness **20**. For example, as shown in FIGS. 1, 2 and 5, an upper suspension strap **40** comprises a clip **42** which is attached to the lower strap suspension point **314** by way of a metal ring **306**.

[0055] As shown in FIG. 2, the head-end lower strap **24** has an intermediate portion **205**, and the foot-end lower strap **22** comprises an intermediate portion **204**. The lower strap harness **20** extends around the rear surface **12** of the baby seat **10**. Specifically, with reference to FIG. 4, the intermediate portion **205** of the head-end lower strap **24** is disposed on the contours of the rear surface **12** of the head end **16** of the baby seat **10**. And, the intermediate portion **204** of the foot-end lower strap **22** is disposed on the contours of the rear surface **12** of the foot end **18** of the baby seat **10**.

[0056] Referring to FIG. 1, an upper suspension strap **40** is attached to the lower strap suspension point **314** and to a structure (symbolically represented by dotted line **11**) located above the baby seat **10**. The upper suspension strap **40** comprises an upper strap first end **41**, an upper strap second end **43**, and an upper strap intermediate portion **45**. A first clip **42** is attached to the upper strap first end **41**, and a second clip **46** is attached to the upper strap second end **43**.

[0057] The upper strap first end **41** is connected to the lower strap suspension point **314**. As disclosed above, the lower strap suspension point comprises a metal ring or equivalent, and the first clip **42** of the upper strap first end **41** is removably attached, for example clipped, to the metal ring or equivalent (for example, see **206** of FIGS. 3A-F).

[0058] The upper strap second end **43** is connected to the structure **11** located above the baby seat **10**. The structure **11** has an exemplary ring **17** attached to it. The second clip **46** of the upper strap second end **43** is removably attached, such as being clipped, to the exemplary ring **17**. In one example, the structure is the ceiling in a home and the exemplary ring **17** is an eye-hook that is screwed or bolted into a beam in the ceiling.

[0059] The clips **42** and **46** are intended to be just one example of the type of connector or device that can be connected to the upper strap **40** first end **41** and second end **43**. Each end (**41, 43**) may comprise any number and types of connectors or device, or none at all. Each end (**41, 43**) may comprise different connectors. The connectors may be

attached to the end in various way such as by sewing, riveting, bonding, or any other means of fastening. Just a few of the numerous connectors or devices that can be attached to the upper strap first end **41**, or the upper strap second end **43**, or both include: a ring, a hook, a clasp, a buckle, an eyelet, and a retractable reel. Those skilled in the art will appreciate that many others are possible.

**[0060]** Similarly, with reference to FIGS. **1** and **3**, the lower strap suspension point **314** may comprise at least one of the following attached to the junction of the ends (**300**, **302** of FIG. **3**) of the head end lower strap **24** and foot end lower strap **22**: a ring, a hook, a clasp, a buckle, an eyelet, and a retractable reel (**1602** of FIGS. **16A-B**).

**[0061]** FIG. **5** shows another perspective view of the baby seat sling. FIGS. **5A-F** illustrate additional details of the baby seat sling. Some details include a lower strap suspension point **314** including the junction of opposing sections of the straps (**22**, **24**) of the lower strap harness **20**. FIG. **5E** shows a ring **306** of the lower strap suspension point **314** (also disclosed in FIG. **3**). In FIG. **5C**, an accessory attachment strap **60** including a connector **61** is connected to the lower strap suspension point **314** and is connected to the lower strap suspension point.

**[0062]** The upper suspension strap **40** comprises a first end **41** shown in greater detail in FIG. **5E**, and a second end **43** shown in greater detail in FIG. **5D**. Connectors such as clips and rings **42** and **46** are attached to the upper strap first end **41** and upper strap second end **43**, respectively.

**[0063]** A length adjustment buckle **52** is attached to the upper suspension strap as shown in FIG. **5E**. The length adjustment buckle **52** may be a sliplock-type buckle or any other type of buckle for adjusting the length of a strap. One type of buckle has a generally flat section with transverse generally parallel openings for a webbing to pass through. The arrangements and sizes of the openings allow the strap length to be adjusted when the strap is loosened between the openings. But, when the webbing is pulled taught it is held firmly in place by friction. The buckle may also comprise a moveable lever to lock and release the webbing. These buckles are commercially available, commonly used, and well known by those having ordinary skill in the art.

**[0064]** Also shown in FIG. **5** is a transverse strap **502** connected to the intermediate portion **205** of the head-end lower strap **24** and to the intermediate portion **204** of the foot-end lower strap **24**. The transverse strap extends over the rear surface **12** of the baby seat **10** and extends from the head end **16** to the foot end **18**. The transverse strap **502** may further comprise a buckle **504**, such as a slide-release buckle. One half of the buckle **504** is connected to the transverse strap **502** and the other half of the buckle **504** is connected to one of the intermediate portions **205** of the head-end lower strap **24** or the intermediate portion **204** of the foot-end lower strap **22**. When extended over the rear surface **12**, the transverse strap provides additional support and stability for the lower strap harness **20** to hold the baby seat **10**.

**[0065]** The baby seat sling also comprises at least one clip **500**. FIG. **1** shows two clips **500(1)** and **500(2)**. FIG. **4** shows two clips **500(2)** and **500(4)**. FIGS. **2** and **5** show four clips **500(1)**, **500(2)**, **500(3)**, and **500(4)**. As illustrated in greater detail in FIGS. **5A** and **5B**, the clip comprises a curved end **506** and an elongated generally flat portion **508** having at least one opening. The arrangements and dimensions of the opening are similar to those of a sliplock-type buckle. The lower

strap harness **20** extends through the at least one opening **510** and the curved end is disposed on the rigid portion of the baby seat.

**[0066]** In one example, two opposed clips **500(1)** and **500(3)** are attached to an intermediate portion **205** of the head-end lower strap **24**. The clips are attached to the strap through the openings (for example **506** and **508**) in the clips. In this way, the clips are moveable when the strap is slack, and secure to the strap when the strap is taught. One of the opposed clips **500(3)** is disposed within a contour of the rear surface **12** of the head end **16** and left side **15** of the baby seat. The other opposed clip **500(1)** is disposed within another contour of the rear surface **12** of the head end **16** of the right side **13** of the baby seat **10**. One exemplary configuration is shown in FIG. **4**.

**[0067]** Similarly, two more opposed clips **500(2)** and **500(4)** are attached in a similar matter to an intermediate portion **204** of the foot-end lower strap **22**. Each of the opposed clips **500(2)** and **500(4)** are disposed within a contour of the rear surface **12** of the foot end **18** of the right side **13** of the baby seat **10**.

**[0068]** The clips secure the lower strap harness **20** to the baby seat **10**, and specifically to the rigid portion of the baby seat. Since nearly all baby seats have different designs, for some baby seats the lower strap harness **20** will be secure without the use of the clips **500**. For other baby seats one or more clips **500** may be used to secure the lower strap harness **20**.

**[0069]** Depending on the baby seat one or more clips **500** may be attached to the rear surface **15**, the front surface, a rigid shell extension, or any other portion of the rigid portion. The one or more clips **500** may be attached to, at, or near the sides **13** and **15**. Many baby seats have a deep ridge around the periphery of the rear surface along the sides of the baby carrier. A clip or clips **500** can be secured in this ridge. Securing the clips is a simple matter of identifying a suitable contour and engaging the curved end of the clip with the contour.

**[0070]** With the above disclosure in mind, some exemplary uses of the baby seat sling are shown in FIGS. **17-20**. FIG. **17** illustrates a baby seat suspended from a hook on a ceiling. FIG. **18** illustrates a baby seat suspended from a frame placed on the ground. FIG. **19** illustrates a baby seat suspended from a door frame, which could equivalently represent a tree limb **[0071]** FIG. **20** illustrates a baby seat suspended from a person. With additional reference to FIG. **1**, the person (**11** of FIG. **20**) is the structure (**11** of FIG. **1**). The upper suspension strap **40** forms a loop so the baby seat can hang from the person's shoulder.

**[0072]** FIGS. **16A** and **16B** show a perspective view of a baby seat sling with the lower strap harness **20** extending in front of a pivotable carrying handle **1604**. The pivotable carrying handle **1604** is a rigid extension extending from the rigid portion of the baby carrier. The lower strap harness **20** may also extend through guides **1606** and **1608** connected to the carrying handle **1604**. In one example, the guides **1606** and **1608** are small rings attached to the handle **20** by a hook-and-loop fastener. In this configuration, the angle of the suspended baby seat can be adjusted by pivoting the carrying handle **1604**. In FIG. **16A** the carrying handle is positioned so the baby seat is in a generally reclined position. In FIG. **16B**, the carrying handle **1604** is pivoted toward the head end **16** of the baby seat thereby forcing the baby seat into a less reclined and more vertical position.

[0073] FIG. 6 shows a perspective view the baby seat sling of FIG. 20. This baby seat sling is identical to that in FIG. 1. In comparing FIGS. 1 and 6, the only difference between them is that in FIG. 1 the upper strap second end 43 is connected to a ceiling 11 or equivalent causing the upper strap 40 to become straight, whereas in FIGS. 6 and 20 the upper strap second end 43 is connected to the lower strap suspension point 314 to form an upper strap loop 60. A length adjustment buckle 52, already disclosed above, is connected to the upper strap 40 for adjusting the size of the upper strap loop 60.

[0074] Equivalently, the upper strap first end 41 may be connected to the lower strap suspension point 314 and the upper strap second end 43 extends through the length adjustment buckle 52, thereby forming an upper strap loop 60 that is adjustable in size. The size of the loop 60 may be made smaller by advancing the second end 43 through the buckle in the direction of the lower strap harness 20. The size of the loop 60 may be made larger by withdrawing the second end 43 in a direction away from the lower strap harness 20.

[0075] Padding may also be attached to the lower strap harness 20 and the upper suspension strap 40. FIG. 20 shows some exemplary padding 1900 and 1902. Various types of padding may be used such as foam padding, cloth padding, and the like. Depending on the placement of the padding, it can serve various functions such as improving user comfort, or improving the safety of the baby seat sling by, for example, covering and protecting elements such as the lower strap suspension point 314 and connections 42 made to it.

[0076] Finally, FIGS. 21-27 shows photos of one exemplary baby seat sling. FIG. 21 shows an upper suspension strap attached to a lower strap suspension point. The head-end lower strap and the foot-end lower strap extend through a channel in a handle. FIG. 22 shows an upper suspension strap attached to a structure above the baby seat. FIG. 23 show a baby seat sling having a lower strap harness, a lower strap suspension point, and an upper suspension strap suspending a baby seat. FIG. 24 shows a clip with the lower strap harness extending through an opening in the clip and a curved end of the clip disposed on the rigid portion of the baby seat. FIG. 25 shows a head-end lower strap disposed on contours of the rear surface of the baby seat, and clips disposed on the rigid portion of the baby seat. FIG. 26 shows a head-end lower strap and a foot-end lower strap disposed on the contours of the rear surface of baby seat. Two clips are attached to the intermediate portion of the head end lower strap, and the clips are disposed within contours of the rear surface of the head end of the baby seat. FIG. 27 shows a left side view of a lower strap harness extending around the baby seat. The head-end lower strap comprises a clip which is disposed in a left-side contour of the baby seat. An accessory strap is connected to the lower strap suspension point and extends generally towards the front surface of the baby seat.

[0077] The foregoing detailed description has discussed only a few of the many forms that this invention can take. It is intended that the foregoing detailed description be understood as an illustration of selected forms that the invention can take and not as a definition of the invention. It is only the following claims, including all equivalents, that are intended to define the scope of this invention.

What is claimed is:

1. A baby seat sling for suspending a baby seat from a structure, wherein the baby seat has a rigid portion, a head end, a foot end, a left side, a right side, wherein the rigid portion comprises a rigid shell having a contoured front sur-

face for supporting a child and a contoured rear surface opposite the seating surface, wherein the rigid portion comprises rigid extensions extending from the rigid shell, the baby seat sling comprising:

a lower strap harness that extends around the rear surface of the baby seat, the lower strap harness comprising,

a head-end lower strap comprising a first strap end, a second strap end, and an

intermediate portion, wherein the intermediate portion is disposed on the contours of the rear surface of the head end of the baby seat;

a foot-end lower strap comprising a first strap end, a second strap end, and an

intermediate portion, wherein the intermediate portion is disposed on the contours of the rear surface of the foot end of the baby seat;

a lower strap suspension point extending above the seating surface of the baby seat, the lower strap suspension point comprising a junction of the first end and the second end of the head-end lower strap and the first end and the second end of the foot-end lower strap; and

an upper suspension strap attached to the lower strap suspension point and to the structure located above the baby seat, wherein the upper suspension strap comprises an upper strap first end, an upper strap second end, and an upper strap intermediate portion.

2. The baby seat sling of claim 1 further comprising a transverse strap connected to intermediate portion of the head-end lower strap and the intermediate portion of the foot-end lower strap.

3. The baby seat sling of claim 2 wherein the transverse strap extends over the rear surface and from the head end to the foot end of the baby seat, and further comprising a buckle connected to one end of the transverse strap and one of: the intermediate portion of the head-end lower strap, or the intermediate portion of the foot-end lower strap.

4. The baby seat sling of claim 1 further comprising a length adjustment buckle attached to the upper suspension strap, wherein the upper suspension strap is threaded through the length adjustment buckle.

5. The baby seat sling of claim 1 wherein the upper strap first end and the upper strap second end are connected to the lower strap suspension point to form an upper strap loop.

6. The baby seat sling of claim 5 further comprising a length adjustment buckle connected to the upper strap for adjusting the size of the upper strap loop.

7. The baby seat sling of claim 1 further comprising:

a length adjustment buckle connected to the upper strap; wherein the upper strap first end is connected to the lower strap suspension point; and

wherein the upper strap second end extends through length adjustment buckle thereby forming an upper strap loop that is adjustable in size.

8. The baby seat sling of claim 1 wherein the upper strap first end is connected to the lower strap suspension point and the upper strap second end is connected to the structure located above the baby seat.

9. The baby seat sling of claim 1 further comprising at least one of a ring, hook, clasp, buckle, eyelet, and retractable reel attached to at least one of the following: the upper strap first end, the upper strap second end.

**10.** The baby seat sling of claim **1** wherein the lower strap suspension point further comprises at least one of the following attached to the junction: a ring, a hook, a clasp, a buckle, an eyelet, a retractable reel.

**11.** The baby seat sling of claim **1** further comprising a handle comprising a channel, wherein the head-end lower strap and the foot-end lower strap extend above the seating surface of the baby seat, through the channel, and to the junction.

**12.** The baby seat sling of claim **1** wherein the first end and the second end of the head-end lower strap are connected, and wherein the first end and the second end of the foot-end lower strap are connected.

**13.** The baby seat sling of claim **1** further comprising at least one clip, the at least one clip comprising a curved end and an elongated generally flat portion having at least one opening, wherein the lower strap harness extends through the at least one opening and the curved end is disposed on the rigid portion of the baby seat.

**14.** The baby seat sling of claim **13** further comprising:

two generally opposed clips attached to the intermediate portion of the head-end lower strap through the at least one opening of the clip, wherein one of the opposed clips is disposed within a contour of the rear surface of the head end and left side of the baby seat, and the other opposed clip is disposed within a contour of the rear surface of the head end and right side of the baby seat; and

two generally opposed clips attached to the intermediate portion of the foot-end lower strap through the at least one opening of the clip, wherein one of the opposed clips is disposed within a contour of the rear surface of the foot end and left side of the baby seat, and the other opposed clip is disposed within a contour of the rear surface of the foot end and right side of the baby seat.

**15.** The baby seat sling of claim **1** further comprising padding attached to at least one of: the lower strap harness, the upper suspension strap.

**16.** The baby seat sling of claim **1** further comprising an accessory attachment strap connected to the lower strap suspension point, wherein the accessory attachment strap extends generally towards the front surface of the baby seat.

**17.** A baby seat sling for suspending a baby seat from a structure, wherein the baby seat has a rigid portion, wherein the rigid portion comprises a rigid shell having a contoured front surface for supporting a child and a contoured rear surface opposite the seating surface, wherein the rigid portion comprises rigid extensions extending from the rigid shell, the baby seat sling comprising:

lower strap harness means for slinging the baby seat with at least one strap which extends from an area above the front surface of the baby seat, over or through the contours of the rigid portion of the baby seat, and back to the area above the front surface;

lower strap suspension point means for connecting opposing sections of the at least one strap together at the area above the front surface of the baby seat; and

upper suspension strap means for suspending the lower strap harness means at the lower strap suspension point means from a structure located above the front surface of the baby seat.

**18.** The invention of claim **17** further comprising height adjustment means for adjusting the suspension height of the baby seat.

**19.** The invention of claim **17** further comprising handle means for joining the opposing sections of the at least one strap above the front surface of the baby seat and for providing a carrying handle.

**20.** The invention of claim **18** further comprising clip means for securing the at least one strap to the rigid portion of baby seat.

**21.** The invention of claim **18** further comprising accessory attachment means for attaching accessories to the lower strap suspension point means.

**22.** The invention of claim **18** further comprising means for adjusting an angle of the suspended baby seat.

\* \* \* \* \*